



Instruction
Harmony Series

Digital Input Modules IMDSI13, IMDSI14, IMDSI22



Preface



The IMDSI13, IMDSI14, and IMDSI22 Digital Input Modules are interfaces used to bring 16 separate process field signals into the Symphony Enterprise Management and Control System. These digital inputs are used by the controller to monitor and control a process.

This instruction explains the digital input (DSI) modules specifications and operation. It details the procedures necessary to complete setup, installation, maintenance, troubleshooting and replacement of the module.

NOTE: The DSI modules are fully compatible with existing INFI 90® OPEN Strategic Enterprise Management Systems.



List of Effective Pages

Total number of pages in this instruction is 43, consisting of the following:

Page No.	Change Date
Preface	Original
List of Effective Pages	Original
iii through viii	Original
1-1 through 1-7	Original
2-1 through 2-7	Original
3-1 through 3-7	Original
4-1 through 4-2	Original
5-1 through 5-3	Original
6-1 through 6-4	Original
7-1	Original
A-1 through A-2	Original
Index-1 through Index-2	Original

NOTE: Changed text or tables are indicated by a vertical bar adjacent to the changed area. Changed figures are indicated by a vertical bar next to the figure caption. The date appears beside the page number.

Table of Contents



Section 1 Introduction	1-1
Overview	1-1
Intended User	1-1
Instruction Content.....	1-1
How to Use this Instruction.....	1-3
Document Conventions	1-3
Glossary of Terms and Abbreviations.....	1-3
Reference Documents.....	1-4
Related Nomenclature	1-4
Specifications.....	1-4
Section 2 Description and Operation	2-1
Introduction.....	2-1
Module Description	2-1
Inputs.....	2-1
Input Circuits.....	2-2
Input Circuit Description.....	2-3
Input Circuit Connections	2-3
Control Logic.....	2-3
Point Data Byte	2-4
Status Byte	2-4
Logic Power.....	2-4
I/O Expander Bus.....	2-5
Universal I/O Expander Bus Interface	2-5
Mounting Hardware	2-5
Section 3 Installation	3-1
Introduction.....	3-1
Special Handling.....	3-1
Unpacking and Inspection.....	3-2
Setup and Physical Installation	3-2
Address Selection Switch (S1).....	3-2
Digital Input Jumper Settings.....	3-4
Termination Configuration	3-5
Physical Installation	3-6
Wiring Connections and Cabling	3-6
Wiring	3-7
Cable Connections	3-7



Table of Contents (continued)

Section 4 Operating Procedures	4-1
Introduction	4-1
Indicators	4-1
Startup Procedures.....	4-2
Section 5 Troubleshooting	5-1
Introduction	5-1
Error Indications and Corrective Action	5-1
Controller Errors	5-1
Module Pin Connections	5-2
Section 6 Maintenance	6-1
Introduction	6-1
Preventive Maintenance Schedule	6-1
Equipment and Tools Required	6-2
Preventive Maintenance Procedures	6-2
Printed Circuit Board Cleaning	6-2
General Cleaning and Washing.....	6-3
Edge Connector Cleaning	6-3
Checking Connections	6-4
Section 7 Repair and Replacement	7-1
Introduction	7-1
Module Repair and Replacement.....	7-1
Appendix A NTDI01 Termination Unit	A-1
Introduction	A-1

List of Figures

No.	Title	Page
1-1.	Harmony Rack I/O Architecture	1-2
2-1.	Digital Input Module Block Diagram	2-2
2-2.	Digital Input Module Circuitry	2-4
2-3.	Mounting Hardware.....	2-6
3-1.	Module Layout.....	3-3

List of Figures



No.	Title	Page
3-2.	Address Select Switch S1 Settings	3-3
3-3.	Cable Connections and Termination.....	3-7
4-1.	Front Panel View	4-1
A-1.	NTDIO1 Dipshunt.....	A-1
A-2.	NTDIO1 Terminal Assignments	A-2

List of Tables

No.	Title	Page
1-1.	Glossary of Terms and Abbreviations.....	1-3
1-2.	Reference Documents.....	1-4
1-3.	Related Nomenclature	1-4
1-4.	Specifications.....	1-5
3-1.	S1 Address Switch Settings Examples	3-4
3-2.	Working Voltage Settings (IMDSI22)	3-4
3-3.	Mode Settings (IMDSI22).....	3-5
5-1.	P3 Input Signal Pin Connections	5-2
5-2.	P1 Power Pin Connections.....	5-3
5-3.	P2 Expander Bus Connections	5-3
6-1.	Preventive Maintenance Schedule.....	6-2
A-1.	NTDIO1 Dipshunt Configuration.....	A-2



Safety Summary



Electrostatic Sensitive Device

Devices labeled with this symbol require special handling precautions as described in the installation section.

GENERAL WARNINGS

Equipment Environment

All components, whether in transportation, operation or storage, must be in a noncorrosive environment.

Electrical Shock Hazard During Maintenance

Disconnect power or take precautions to insure that contact with energized parts is avoided when servicing.

SPECIFIC WARNINGS

Disconnect power before installing dipshunts on the module mounting unit backplane. Failure to do so will result in contact with cabinet areas that could cause severe or fatal shock. (p. 3-6, 5-2)

Never clean electrical parts or components with live power present. Doing so exposes you to an electrical shock hazard. (p. 6-3)

Wear eye protection whenever working with cleaning solvents. When removing solvents from printed circuit boards using compressed air, injury to the eyes could result from splashing solvent as it is removed from the printed circuit board. (p. 6-3)

There are exposed AC and DC connections inside the cabinet. These exposed electrical connections present a shock hazard that can cause injury or death. (p. 6-4)

If input or output circuits are a shock hazard after disconnecting system power at the power entry panel, then the door of the cabinet containing these externally powered circuits must be marked with a warning stating that multiple power sources exist. (p. 6-4)

Support Services



ABB will provide assistance in the operation and repair of its products. Requests for sales or application services should be made to your nearest sales or service office. ABB can also provide installation, repair and maintenance contract services.

When ordering parts, use nomenclature or part numbers and part descriptions from equipment manuals. Parts without a description must be ordered from the nearest sales or service office. Recommended spare parts lists, including prices are available through the nearest sales or service office.

ABB has modern training facilities available for training your personnel. On-site training is also available. Contact your nearest ABB sales office for specific information and scheduling.

Additional copies of this instruction, or other instructions, can be obtained from the nearest ABB sales office at a reasonable charge.



Trademarks and Registrations

Registrations and trademarks used in this document include:

® INFI 90

Registered trademark of Elsig Bailey Process Automation.

Preface



The IMDSI13, IMDSI14, and IMDSI22 Digital Input Modules are interfaces used to bring 16 separate process field signals into the Symphony Enterprise Management and Control System. These digital inputs are used by the controller to monitor and control a process.

This instruction explains the digital input (DSI) modules specifications and operation. It details the procedures necessary to complete setup, installation, maintenance, troubleshooting and replacement of the module.

NOTE: The DSI modules are fully compatible with existing INFI 90® OPEN Strategic Enterprise Management Systems.



List of Effective Pages

Total number of pages in this instruction is 43, consisting of the following:

Page No.	Change Date
Preface	Original
List of Effective Pages	Original
iii through viii	Original
1-1 through 1-7	Original
2-1 through 2-7	Original
3-1 through 3-7	Original
4-1 through 4-2	Original
5-1 through 5-3	Original
6-1 through 6-4	Original
7-1	Original
A-1 through A-2	Original
Index-1 through Index-2	Original

NOTE: Changed text or tables are indicated by a vertical bar adjacent to the changed area. Changed figures are indicated by a vertical bar next to the figure caption. The date appears beside the page number.

Table of Contents



Section 1 Introduction	1-1
Overview	1-1
Intended User	1-1
Instruction Content.....	1-1
How to Use this Instruction.....	1-3
Document Conventions	1-3
Glossary of Terms and Abbreviations.....	1-3
Reference Documents.....	1-4
Related Nomenclature	1-4
Specifications.....	1-4
Section 2 Description and Operation	2-1
Introduction.....	2-1
Module Description	2-1
Inputs.....	2-1
Input Circuits.....	2-2
Input Circuit Description.....	2-3
Input Circuit Connections	2-3
Control Logic.....	2-3
Point Data Byte	2-4
Status Byte	2-4
Logic Power.....	2-4
I/O Expander Bus.....	2-5
Universal I/O Expander Bus Interface	2-5
Mounting Hardware	2-5
Section 3 Installation	3-1
Introduction.....	3-1
Special Handling.....	3-1
Unpacking and Inspection.....	3-2
Setup and Physical Installation	3-2
Address Selection Switch (S1).....	3-2
Digital Input Jumper Settings.....	3-4
Termination Configuration	3-5
Physical Installation	3-6
Wiring Connections and Cabling	3-6
Wiring	3-7
Cable Connections	3-7



Table of Contents (continued)

Section 4 Operating Procedures	4-1
Introduction	4-1
Indicators	4-1
Startup Procedures.....	4-2
Section 5 Troubleshooting	5-1
Introduction	5-1
Error Indications and Corrective Action	5-1
Controller Errors	5-1
Module Pin Connections	5-2
Section 6 Maintenance	6-1
Introduction	6-1
Preventive Maintenance Schedule	6-1
Equipment and Tools Required	6-2
Preventive Maintenance Procedures	6-2
Printed Circuit Board Cleaning	6-2
General Cleaning and Washing.....	6-3
Edge Connector Cleaning	6-3
Checking Connections	6-4
Section 7 Repair and Replacement	7-1
Introduction	7-1
Module Repair and Replacement.....	7-1
Appendix A NTDI01 Termination Unit	A-1
Introduction	A-1

List of Figures

No.	Title	Page
1-1.	Harmony Rack I/O Architecture	1-2
2-1.	Digital Input Module Block Diagram	2-2
2-2.	Digital Input Module Circuitry	2-4
2-3.	Mounting Hardware.....	2-6
3-1.	Module Layout.....	3-3

List of Figures



<i>No.</i>	<i>Title</i>	<i>Page</i>
3-2.	Address Select Switch S1 Settings	3-3
3-3.	Cable Connections and Termination.....	3-7
4-1.	Front Panel View	4-1
A-1.	NTDIO1 Dipshunt.....	A-1
A-2.	NTDIO1 Terminal Assignments	A-2

List of Tables

<i>No.</i>	<i>Title</i>	<i>Page</i>
1-1.	Glossary of Terms and Abbreviations.....	1-3
1-2.	Reference Documents.....	1-4
1-3.	Related Nomenclature	1-4
1-4.	Specifications.....	1-5
3-1.	S1 Address Switch Settings Examples	3-4
3-2.	Working Voltage Settings (IMDSI22)	3-4
3-3.	Mode Settings (IMDSI22).....	3-5
5-1.	P3 Input Signal Pin Connections	5-2
5-2.	P1 Power Pin Connections.....	5-3
5-3.	P2 Expander Bus Connections	5-3
6-1.	Preventive Maintenance Schedule.....	6-2
A-1.	NTDIO1 Dipshunt Configuration.....	A-2



Safety Summary



Electrostatic Sensitive Device

Devices labeled with this symbol require special handling precautions as described in the installation section.

GENERAL WARNINGS

Equipment Environment

All components, whether in transportation, operation or storage, must be in a noncorrosive environment.

Electrical Shock Hazard During Maintenance

Disconnect power or take precautions to insure that contact with energized parts is avoided when servicing.

SPECIFIC WARNINGS

Disconnect power before installing dipshunts on the module mounting unit backplane. Failure to do so will result in contact with cabinet areas that could cause severe or fatal shock. (p. 3-6, 5-2)

Never clean electrical parts or components with live power present. Doing so exposes you to an electrical shock hazard. (p. 6-3)

Wear eye protection whenever working with cleaning solvents. When removing solvents from printed circuit boards using compressed air, injury to the eyes could result from splashing solvent as it is removed from the printed circuit board. (p. 6-3)

There are exposed AC and DC connections inside the cabinet. These exposed electrical connections present a shock hazard that can cause injury or death. (p. 6-4)

If input or output circuits are a shock hazard after disconnecting system power at the power entry panel, then the door of the cabinet containing these externally powered circuits must be marked with a warning stating that multiple power sources exist. (p. 6-4)

Support Services



ABB will provide assistance in the operation and repair of its products. Requests for sales or application services should be made to your nearest sales or service office. ABB can also provide installation, repair and maintenance contract services.

When ordering parts, use nomenclature or part numbers and part descriptions from equipment manuals. Parts without a description must be ordered from the nearest sales or service office. Recommended spare parts lists, including prices are available through the nearest sales or service office.

ABB has modern training facilities available for training your personnel. On-site training is also available. Contact your nearest ABB sales office for specific information and scheduling.

Additional copies of this instruction, or other instructions, can be obtained from the nearest ABB sales office at a reasonable charge.



Trademarks and Registrations

Registrations and trademarks used in this document include:

® INFI 90 Registered trademark of Elsig Bailey Process Automation.

Preface



The IMDSI13, IMDSI14, and IMDSI22 Digital Input Modules are interfaces used to bring 16 separate process field signals into the Symphony Enterprise Management and Control System. These digital inputs are used by the controller to monitor and control a process.

This instruction explains the digital input (DSI) modules specifications and operation. It details the procedures necessary to complete setup, installation, maintenance, troubleshooting and replacement of the module.

NOTE: The DSI modules are fully compatible with existing INFI 90® OPEN Strategic Enterprise Management Systems.



List of Effective Pages

Total number of pages in this instruction is 43, consisting of the following:

Page No.	Change Date
Preface	Original
List of Effective Pages	Original
iii through viii	Original
1-1 through 1-7	Original
2-1 through 2-7	Original
3-1 through 3-7	Original
4-1 through 4-2	Original
5-1 through 5-3	Original
6-1 through 6-4	Original
7-1	Original
A-1 through A-2	Original
Index-1 through Index-2	Original

NOTE: Changed text or tables are indicated by a vertical bar adjacent to the changed area. Changed figures are indicated by a vertical bar next to the figure caption. The date appears beside the page number.

Table of Contents



Section 1 Introduction	1-1
Overview	1-1
Intended User	1-1
Instruction Content.....	1-1
How to Use this Instruction.....	1-3
Document Conventions	1-3
Glossary of Terms and Abbreviations.....	1-3
Reference Documents.....	1-4
Related Nomenclature	1-4
Specifications.....	1-4
Section 2 Description and Operation	2-1
Introduction.....	2-1
Module Description	2-1
Inputs.....	2-1
Input Circuits.....	2-2
Input Circuit Description.....	2-3
Input Circuit Connections	2-3
Control Logic.....	2-3
Point Data Byte	2-4
Status Byte	2-4
Logic Power.....	2-4
I/O Expander Bus.....	2-5
Universal I/O Expander Bus Interface	2-5
Mounting Hardware	2-5
Section 3 Installation	3-1
Introduction.....	3-1
Special Handling.....	3-1
Unpacking and Inspection.....	3-2
Setup and Physical Installation	3-2
Address Selection Switch (S1).....	3-2
Digital Input Jumper Settings.....	3-4
Termination Configuration	3-5
Physical Installation	3-6
Wiring Connections and Cabling	3-6
Wiring	3-7
Cable Connections	3-7



Table of Contents (continued)

Section 4 Operating Procedures	4-1
Introduction	4-1
Indicators	4-1
Startup Procedures.....	4-2
Section 5 Troubleshooting	5-1
Introduction	5-1
Error Indications and Corrective Action	5-1
Controller Errors	5-1
Module Pin Connections	5-2
Section 6 Maintenance	6-1
Introduction	6-1
Preventive Maintenance Schedule	6-1
Equipment and Tools Required	6-2
Preventive Maintenance Procedures	6-2
Printed Circuit Board Cleaning	6-2
General Cleaning and Washing.....	6-3
Edge Connector Cleaning	6-3
Checking Connections	6-4
Section 7 Repair and Replacement	7-1
Introduction	7-1
Module Repair and Replacement.....	7-1
Appendix A NTDI01 Termination Unit	A-1
Introduction	A-1

List of Figures

No.	Title	Page
1-1.	Harmony Rack I/O Architecture	1-2
2-1.	Digital Input Module Block Diagram	2-2
2-2.	Digital Input Module Circuitry	2-4
2-3.	Mounting Hardware.....	2-6
3-1.	Module Layout.....	3-3

List of Figures



No.	Title	Page
3-2.	Address Select Switch S1 Settings	3-3
3-3.	Cable Connections and Termination.....	3-7
4-1.	Front Panel View	4-1
A-1.	NTDIO1 Dipshunt.....	A-1
A-2.	NTDIO1 Terminal Assignments	A-2

List of Tables

No.	Title	Page
1-1.	Glossary of Terms and Abbreviations.....	1-3
1-2.	Reference Documents.....	1-4
1-3.	Related Nomenclature	1-4
1-4.	Specifications.....	1-5
3-1.	S1 Address Switch Settings Examples	3-4
3-2.	Working Voltage Settings (IMDSI22)	3-4
3-3.	Mode Settings (IMDSI22).....	3-5
5-1.	P3 Input Signal Pin Connections	5-2
5-2.	P1 Power Pin Connections.....	5-3
5-3.	P2 Expander Bus Connections	5-3
6-1.	Preventive Maintenance Schedule.....	6-2
A-1.	NTDIO1 Dipshunt Configuration.....	A-2



Safety Summary



Electrostatic Sensitive Device

Devices labeled with this symbol require special handling precautions as described in the installation section.

GENERAL WARNINGS

Equipment Environment

All components, whether in transportation, operation or storage, must be in a noncorrosive environment.

Electrical Shock Hazard During Maintenance

Disconnect power or take precautions to insure that contact with energized parts is avoided when servicing.

SPECIFIC WARNINGS

Disconnect power before installing dipshunts on the module mounting unit backplane. Failure to do so will result in contact with cabinet areas that could cause severe or fatal shock. (p. 3-6, 5-2)

Never clean electrical parts or components with live power present. Doing so exposes you to an electrical shock hazard. (p. 6-3)

Wear eye protection whenever working with cleaning solvents. When removing solvents from printed circuit boards using compressed air, injury to the eyes could result from splashing solvent as it is removed from the printed circuit board. (p. 6-3)

There are exposed AC and DC connections inside the cabinet. These exposed electrical connections present a shock hazard that can cause injury or death. (p. 6-4)

If input or output circuits are a shock hazard after disconnecting system power at the power entry panel, then the door of the cabinet containing these externally powered circuits must be marked with a warning stating that multiple power sources exist. (p. 6-4)

Support Services



ABB will provide assistance in the operation and repair of its products. Requests for sales or application services should be made to your nearest sales or service office. ABB can also provide installation, repair and maintenance contract services.

When ordering parts, use nomenclature or part numbers and part descriptions from equipment manuals. Parts without a description must be ordered from the nearest sales or service office. Recommended spare parts lists, including prices are available through the nearest sales or service office.

ABB has modern training facilities available for training your personnel. On-site training is also available. Contact your nearest ABB sales office for specific information and scheduling.

Additional copies of this instruction, or other instructions, can be obtained from the nearest ABB sales office at a reasonable charge.



Trademarks and Registrations

Registrations and trademarks used in this document include:

® INFI 90 Registered trademark of Elsig Bailey Process Automation.

Preface



The IMDSI13, IMDSI14, and IMDSI22 Digital Input Modules are interfaces used to bring 16 separate process field signals into the Symphony Enterprise Management and Control System. These digital inputs are used by the controller to monitor and control a process.

This instruction explains the digital input (DSI) modules specifications and operation. It details the procedures necessary to complete setup, installation, maintenance, troubleshooting and replacement of the module.

NOTE: The DSI modules are fully compatible with existing INFI 90® OPEN Strategic Enterprise Management Systems.



List of Effective Pages

Total number of pages in this instruction is 43, consisting of the following:

Page No.	Change Date
Preface	Original
List of Effective Pages	Original
iii through viii	Original
1-1 through 1-7	Original
2-1 through 2-7	Original
3-1 through 3-7	Original
4-1 through 4-2	Original
5-1 through 5-3	Original
6-1 through 6-4	Original
7-1	Original
A-1 through A-2	Original
Index-1 through Index-2	Original

NOTE: Changed text or tables are indicated by a vertical bar adjacent to the changed area. Changed figures are indicated by a vertical bar next to the figure caption. The date appears beside the page number.

Table of Contents



Section 1 Introduction	1-1
Overview	1-1
Intended User	1-1
Instruction Content.....	1-1
How to Use this Instruction.....	1-3
Document Conventions	1-3
Glossary of Terms and Abbreviations.....	1-3
Reference Documents.....	1-4
Related Nomenclature	1-4
Specifications.....	1-4
Section 2 Description and Operation	2-1
Introduction.....	2-1
Module Description	2-1
Inputs.....	2-1
Input Circuits.....	2-2
Input Circuit Description.....	2-3
Input Circuit Connections	2-3
Control Logic.....	2-3
Point Data Byte	2-4
Status Byte	2-4
Logic Power.....	2-4
I/O Expander Bus.....	2-5
Universal I/O Expander Bus Interface	2-5
Mounting Hardware	2-5
Section 3 Installation	3-1
Introduction.....	3-1
Special Handling.....	3-1
Unpacking and Inspection.....	3-2
Setup and Physical Installation	3-2
Address Selection Switch (S1).....	3-2
Digital Input Jumper Settings.....	3-4
Termination Configuration	3-5
Physical Installation	3-6
Wiring Connections and Cabling	3-6
Wiring	3-7
Cable Connections	3-7



Table of Contents (continued)

Section 4 Operating Procedures	4-1
Introduction	4-1
Indicators	4-1
Startup Procedures.....	4-2
Section 5 Troubleshooting	5-1
Introduction	5-1
Error Indications and Corrective Action	5-1
Controller Errors	5-1
Module Pin Connections	5-2
Section 6 Maintenance	6-1
Introduction	6-1
Preventive Maintenance Schedule	6-1
Equipment and Tools Required	6-2
Preventive Maintenance Procedures	6-2
Printed Circuit Board Cleaning	6-2
General Cleaning and Washing.....	6-3
Edge Connector Cleaning	6-3
Checking Connections	6-4
Section 7 Repair and Replacement	7-1
Introduction	7-1
Module Repair and Replacement.....	7-1
Appendix A NTDI01 Termination Unit	A-1
Introduction	A-1

List of Figures

No.	Title	Page
1-1.	Harmony Rack I/O Architecture	1-2
2-1.	Digital Input Module Block Diagram	2-2
2-2.	Digital Input Module Circuitry	2-4
2-3.	Mounting Hardware.....	2-6
3-1.	Module Layout.....	3-3

List of Figures



No.	Title	Page
3-2.	Address Select Switch S1 Settings	3-3
3-3.	Cable Connections and Termination.....	3-7
4-1.	Front Panel View	4-1
A-1.	NTDIO1 Dipshunt.....	A-1
A-2.	NTDIO1 Terminal Assignments	A-2

List of Tables

No.	Title	Page
1-1.	Glossary of Terms and Abbreviations.....	1-3
1-2.	Reference Documents.....	1-4
1-3.	Related Nomenclature	1-4
1-4.	Specifications.....	1-5
3-1.	S1 Address Switch Settings Examples	3-4
3-2.	Working Voltage Settings (IMDSI22)	3-4
3-3.	Mode Settings (IMDSI22).....	3-5
5-1.	P3 Input Signal Pin Connections	5-2
5-2.	P1 Power Pin Connections.....	5-3
5-3.	P2 Expander Bus Connections	5-3
6-1.	Preventive Maintenance Schedule.....	6-2
A-1.	NTDIO1 Dipshunt Configuration.....	A-2



Safety Summary



Electrostatic Sensitive Device

Devices labeled with this symbol require special handling precautions as described in the installation section.

GENERAL WARNINGS

Equipment Environment

All components, whether in transportation, operation or storage, must be in a noncorrosive environment.

Electrical Shock Hazard During Maintenance

Disconnect power or take precautions to insure that contact with energized parts is avoided when servicing.

SPECIFIC WARNINGS

Disconnect power before installing dipshunts on the module mounting unit backplane. Failure to do so will result in contact with cabinet areas that could cause severe or fatal shock. (p. 3-6, 5-2)

Never clean electrical parts or components with live power present. Doing so exposes you to an electrical shock hazard. (p. 6-3)

Wear eye protection whenever working with cleaning solvents. When removing solvents from printed circuit boards using compressed air, injury to the eyes could result from splashing solvent as it is removed from the printed circuit board. (p. 6-3)

There are exposed AC and DC connections inside the cabinet. These exposed electrical connections present a shock hazard that can cause injury or death. (p. 6-4)

If input or output circuits are a shock hazard after disconnecting system power at the power entry panel, then the door of the cabinet containing these externally powered circuits must be marked with a warning stating that multiple power sources exist. (p. 6-4)

Support Services



ABB will provide assistance in the operation and repair of its products. Requests for sales or application services should be made to your nearest sales or service office. ABB can also provide installation, repair and maintenance contract services.

When ordering parts, use nomenclature or part numbers and part descriptions from equipment manuals. Parts without a description must be ordered from the nearest sales or service office. Recommended spare parts lists, including prices are available through the nearest sales or service office.

ABB has modern training facilities available for training your personnel. On-site training is also available. Contact your nearest ABB sales office for specific information and scheduling.

Additional copies of this instruction, or other instructions, can be obtained from the nearest ABB sales office at a reasonable charge.



Trademarks and Registrations

Registrations and trademarks used in this document include:

® INFI 90

Registered trademark of Elsig Bailey Process Automation.

Preface



The IMDSI13, IMDSI14, and IMDSI22 Digital Input Modules are interfaces used to bring 16 separate process field signals into the Symphony Enterprise Management and Control System. These digital inputs are used by the controller to monitor and control a process.

This instruction explains the digital input (DSI) modules specifications and operation. It details the procedures necessary to complete setup, installation, maintenance, troubleshooting and replacement of the module.

NOTE: The DSI modules are fully compatible with existing INFI 90® OPEN Strategic Enterprise Management Systems.



List of Effective Pages

Total number of pages in this instruction is 43, consisting of the following:

Page No.	Change Date
Preface	Original
List of Effective Pages	Original
iii through viii	Original
1-1 through 1-7	Original
2-1 through 2-7	Original
3-1 through 3-7	Original
4-1 through 4-2	Original
5-1 through 5-3	Original
6-1 through 6-4	Original
7-1	Original
A-1 through A-2	Original
Index-1 through Index-2	Original

NOTE: Changed text or tables are indicated by a vertical bar adjacent to the changed area. Changed figures are indicated by a vertical bar next to the figure caption. The date appears beside the page number.

Table of Contents



Section 1 Introduction	1-1
Overview	1-1
Intended User	1-1
Instruction Content.....	1-1
How to Use this Instruction.....	1-3
Document Conventions	1-3
Glossary of Terms and Abbreviations.....	1-3
Reference Documents.....	1-4
Related Nomenclature	1-4
Specifications.....	1-4
Section 2 Description and Operation	2-1
Introduction.....	2-1
Module Description	2-1
Inputs.....	2-1
Input Circuits.....	2-2
Input Circuit Description.....	2-3
Input Circuit Connections	2-3
Control Logic.....	2-3
Point Data Byte	2-4
Status Byte	2-4
Logic Power.....	2-4
I/O Expander Bus.....	2-5
Universal I/O Expander Bus Interface	2-5
Mounting Hardware	2-5
Section 3 Installation	3-1
Introduction.....	3-1
Special Handling.....	3-1
Unpacking and Inspection.....	3-2
Setup and Physical Installation	3-2
Address Selection Switch (S1).....	3-2
Digital Input Jumper Settings.....	3-4
Termination Configuration	3-5
Physical Installation	3-6
Wiring Connections and Cabling	3-6
Wiring	3-7
Cable Connections	3-7



Table of Contents (continued)

Section 4 Operating Procedures	4-1
Introduction	4-1
Indicators	4-1
Startup Procedures.....	4-2
Section 5 Troubleshooting	5-1
Introduction	5-1
Error Indications and Corrective Action	5-1
Controller Errors	5-1
Module Pin Connections	5-2
Section 6 Maintenance	6-1
Introduction	6-1
Preventive Maintenance Schedule	6-1
Equipment and Tools Required	6-2
Preventive Maintenance Procedures	6-2
Printed Circuit Board Cleaning	6-2
General Cleaning and Washing.....	6-3
Edge Connector Cleaning	6-3
Checking Connections	6-4
Section 7 Repair and Replacement	7-1
Introduction	7-1
Module Repair and Replacement.....	7-1
Appendix A NTDI01 Termination Unit	A-1
Introduction	A-1

List of Figures

No.	Title	Page
1-1.	Harmony Rack I/O Architecture	1-2
2-1.	Digital Input Module Block Diagram	2-2
2-2.	Digital Input Module Circuitry	2-4
2-3.	Mounting Hardware.....	2-6
3-1.	Module Layout.....	3-3

List of Figures



<i>No.</i>	<i>Title</i>	<i>Page</i>
3-2.	Address Select Switch S1 Settings	3-3
3-3.	Cable Connections and Termination.....	3-7
4-1.	Front Panel View	4-1
A-1.	NTDIO1 Dipshunt.....	A-1
A-2.	NTDIO1 Terminal Assignments	A-2

List of Tables

<i>No.</i>	<i>Title</i>	<i>Page</i>
1-1.	Glossary of Terms and Abbreviations.....	1-3
1-2.	Reference Documents.....	1-4
1-3.	Related Nomenclature	1-4
1-4.	Specifications.....	1-5
3-1.	S1 Address Switch Settings Examples	3-4
3-2.	Working Voltage Settings (IMDSI22)	3-4
3-3.	Mode Settings (IMDSI22).....	3-5
5-1.	P3 Input Signal Pin Connections	5-2
5-2.	P1 Power Pin Connections.....	5-3
5-3.	P2 Expander Bus Connections	5-3
6-1.	Preventive Maintenance Schedule.....	6-2
A-1.	NTDIO1 Dipshunt Configuration.....	A-2



Safety Summary



Electrostatic Sensitive Device

Devices labeled with this symbol require special handling precautions as described in the installation section.

GENERAL WARNINGS

Equipment Environment

All components, whether in transportation, operation or storage, must be in a noncorrosive environment.

Electrical Shock Hazard During Maintenance

Disconnect power or take precautions to insure that contact with energized parts is avoided when servicing.

SPECIFIC WARNINGS

Disconnect power before installing dipshunts on the module mounting unit backplane. Failure to do so will result in contact with cabinet areas that could cause severe or fatal shock. (p. 3-6, 5-2)

Never clean electrical parts or components with live power present. Doing so exposes you to an electrical shock hazard. (p. 6-3)

Wear eye protection whenever working with cleaning solvents. When removing solvents from printed circuit boards using compressed air, injury to the eyes could result from splashing solvent as it is removed from the printed circuit board. (p. 6-3)

There are exposed AC and DC connections inside the cabinet. These exposed electrical connections present a shock hazard that can cause injury or death. (p. 6-4)

If input or output circuits are a shock hazard after disconnecting system power at the power entry panel, then the door of the cabinet containing these externally powered circuits must be marked with a warning stating that multiple power sources exist. (p. 6-4)

Support Services



ABB will provide assistance in the operation and repair of its products. Requests for sales or application services should be made to your nearest sales or service office. ABB can also provide installation, repair and maintenance contract services.

When ordering parts, use nomenclature or part numbers and part descriptions from equipment manuals. Parts without a description must be ordered from the nearest sales or service office. Recommended spare parts lists, including prices are available through the nearest sales or service office.

ABB has modern training facilities available for training your personnel. On-site training is also available. Contact your nearest ABB sales office for specific information and scheduling.

Additional copies of this instruction, or other instructions, can be obtained from the nearest ABB sales office at a reasonable charge.



Trademarks and Registrations

Registrations and trademarks used in this document include:

® INFI 90

Registered trademark of Elsig Bailey Process Automation.



Overview

The IMDSI13, IMDSI14, and IMDSI22 Digital Input Modules provide 16 separate digital signals into the Symphony Enterprise Management and Control System for processing and monitoring. They interface process field inputs to the system. A contact closure or switch is an example of a device that supplies a digital signal. The controller provides the control functions, I/O modules provide the inputs and outputs. Three variations of the DSI modules are described in this instruction:

- IMDSI13 - 24 VDC inputs.
- IMDSI14 - 48 VDC inputs.
- IMDSI22 - 120 VAC, 24 VDC, 48 VDC, or 125 VDC inputs.

Figure 1-1 shows a Harmony area controller and the Harmony rack controllers using the rack I/O modules for I/O interface.

Intended User

Personnel installing, operating, or maintaining the DSI modules should read this instruction before performing any installation, operation, or maintenance procedures. Installation requires an engineer or technician with experience handling electronic circuitry. Those working with the digital output module should have experience working with and know the precautions to take around AC/DC power. A knowledge of the Symphony system and electronic principles is also required.

Instruction Content

This instruction consists of the following sections:

- | | |
|---------------------------|---|
| Introduction | Contains a brief description, general usage information and technical specifications. |
| Description and Operation | Uses block diagrams and schematics to explain module operation and input circuitry. |

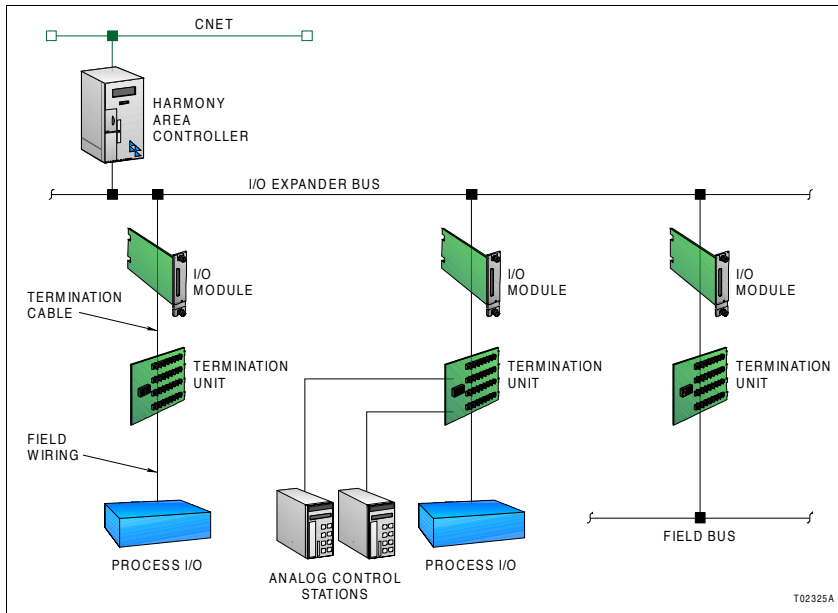

Figure 1-1. Harmony Rack I/O Architecture

Installation Covers the preliminary steps to install the module and prepare for operation. It covers dipswitch and jumper settings, mounting, wiring connections, cabling and preoperational checks.

Operating Procedures Provides information on front panel indicators and startup procedures.

Troubleshooting Explains the meaning of error indications and contains troubleshooting procedures.

Maintenance Contains scheduled maintenance tasks and procedures.

Repair and Replacement Contains procedures that explain how to replace the module.

Appendix **Appendix A** provides configuration information for the NTDI01 termination unit.

How to Use this Instruction

Read this instruction in sequence. It is important to become familiar with the entire contents of this instruction before using the modules. Refer to a specific section for information as needed.

1. Read the operating procedures section before installing the module.
2. Perform the steps in the installation section.
3. Refer to the troubleshooting section to resolve problems if they occur.
4. Refer to the maintenance section for scheduled maintenance requirements.
5. Refer to the repair and replacement procedures to replace a module.

Document Conventions

The ? in a nomenclature item indicates variables for that position, i.e., IMDS11?.

Glossary of Terms and Abbreviations

Table 1-1 contains those terms and abbreviations that are unique or have a definition that is different from standard industry usage.

Table 1-1. Glossary of Terms and Abbreviations

Term	Definition
Cnet	Symphony system advanced data communication highway.
Controlway	High speed, redundant, peer-to-peer communication link. Used to transfer information between intelligent modules within a Harmony control unit.
Function code (FC)	An algorithm which manipulates specific functions. These functions are linked together to form the control strategy.
I/O expander bus	Parallel communication bus between the Harmony rack controllers and rack I/O modules.



Table 1-1. Glossary of Terms and Abbreviations *(continued)*

Term	Definition
Module mounting unit (MMU)	A card cage that provides electrical and communication support for Harmony rack modules.
Termination unit (TU)	Provides input/output connection between plant equipment and the Harmony rack modules.

Reference Documents

Table 1-2 lists instructions for equipment that is referenced in this instruction.

Table 1-2. Reference Documents

Number	Document
WBPEEU1200502??	Module Mounting Unit (IEMMU11, IEMMU12, IEMMU21, IEMMU22)
WBPEEU1210504??	Symphony Function Code Application Manual
WBPEEU1260042??	Digital Input Termination Unit (NTDI01)
WBPEEU1270003??	Composer, Automation Architect

Related Nomenclature

Table 1-3 lists nomenclature related to the IMDSI13, IMDSI14, and IMDSI22 modules.

Table 1-3. Related Nomenclature

Nomenclature	Description
IEMMU11, EMMU12, IEMMU21, IEMMU22	Module mounting unit
NFTP01	Field termination panel

Specifications

Table 1-4 contains the specifications for the IMDSI13, IMDSI14, and IMDSI22 digital input modules.

Table 1-4. Specifications

Property	Characteristic/Value																																
Power requirements Operating voltage	95 mA at 5 VDC (typical), 115 mA maximum																																
Over voltage category (ANSI/ISA S82.01-1994 and IEC 61010-1)	I for power I for circuits >150 V, II for circuits <150 V																																
Digital inputs	16 channels <table border="1" style="margin-left: 20px;"> <thead> <tr> <th>IMDSH13/22</th> <th>IMDSH14/22</th> <th colspan="2">IMDSI22</th> </tr> </thead> <tbody> <tr> <td>24 VDC</td> <td>48 VDC</td> <td>125 VDC</td> <td>120 VAC</td> </tr> <tr> <td>5.5 mA</td> <td>4.7 mA</td> <td>4.5 mA</td> <td>6 mA</td> </tr> <tr> <td>19.5 VDC</td> <td>26.7 VDC</td> <td>90.5 VDC</td> <td>81 VAC</td> </tr> <tr> <td>13 VDC</td> <td>13 VDC</td> <td>55 VDC</td> <td>45 VAC</td> </tr> <tr> <td>4 mA at 19.5 VDC</td> <td>2 mA at 26.7 VDC</td> <td>2.4 mA at 90.5 VDC</td> <td>3.8 mA at 81 VAC</td> </tr> <tr> <td>50 nA (at V_{in} ≤ 10.5 VDC)</td> <td>50 nA (at V_{in} ≤ 10.5 VDC)</td> <td>1 μA (at V_{in} ≤ 50.8 VDC)</td> <td>1.6 mA (at V_{in} ≤ 45 VAC)</td> </tr> <tr> <td colspan="4" style="text-align: center;">17 ms (fixed)</td> </tr> </tbody> </table>	IMDSH13/22	IMDSH14/22	IMDSI22		24 VDC	48 VDC	125 VDC	120 VAC	5.5 mA	4.7 mA	4.5 mA	6 mA	19.5 VDC	26.7 VDC	90.5 VDC	81 VAC	13 VDC	13 VDC	55 VDC	45 VAC	4 mA at 19.5 VDC	2 mA at 26.7 VDC	2.4 mA at 90.5 VDC	3.8 mA at 81 VAC	50 nA (at V_{in} ≤ 10.5 VDC)	50 nA (at V_{in} ≤ 10.5 VDC)	1 μ A (at V_{in} ≤ 50.8 VDC)	1.6 mA (at V_{in} ≤ 45 VAC)	17 ms (fixed)			
IMDSH13/22	IMDSH14/22	IMDSI22																															
24 VDC	48 VDC	125 VDC	120 VAC																														
5.5 mA	4.7 mA	4.5 mA	6 mA																														
19.5 VDC	26.7 VDC	90.5 VDC	81 VAC																														
13 VDC	13 VDC	55 VDC	45 VAC																														
4 mA at 19.5 VDC	2 mA at 26.7 VDC	2.4 mA at 90.5 VDC	3.8 mA at 81 VAC																														
50 nA (at V_{in} ≤ 10.5 VDC)	50 nA (at V_{in} ≤ 10.5 VDC)	1 μ A (at V_{in} ≤ 50.8 VDC)	1.6 mA (at V_{in} ≤ 45 VAC)																														
17 ms (fixed)																																	
Mounting	Occupies one slot in a standard module mounting unit																																
Environmental Ambient temperature (per IEC 68-2-1, 2,14) Relative humidity (per IEC 68-2-3) Atmospheric pressure Air quality (per ISA S71.04, Class LA, LB, LC - level 1)	Temperature rating within the cabinet or enclosure applies. Internal cabinet rating: 0° to 70° C (32° to 158° F) 5% to 95% up to 55° C (131° F), noncondensing 5% to 45% at 70° C (158° F), noncondensing Pollution degree: 1 Sea level to 3 km (1.86 miles) Noncorrosive																																
Insulation (IEC 61010-1, IEC 60255-5, IEC 60060)	<table border="1" style="margin-left: 20px;"> <thead> <tr> <th>Test</th> <th>Common Mode</th> <th>Normal Mode</th> </tr> </thead> <tbody> <tr> <td>Insulation resistance (100/500 VDC)</td> <td>100 M</td> <td>N/A</td> </tr> <tr> <td>Dielectric VAC (45 -65 Hz) or VDC</td> <td>1.4 kV_{RMS}/1min. or 1.95 kVDC/1min.</td> <td>N/A</td> </tr> <tr> <td>Impulse voltage</td> <td>± 2.55 kVp</td> <td>± 1 kVp</td> </tr> </tbody> </table>	Test	Common Mode	Normal Mode	Insulation resistance (100/500 VDC)	100 M	N/A	Dielectric VAC (45 -65 Hz) or VDC	1.4 kV _{RMS} /1min. or 1.95 kVDC/1min.	N/A	Impulse voltage	± 2.55 kVp	± 1 kVp																				
Test	Common Mode	Normal Mode																															
Insulation resistance (100/500 VDC)	100 M	N/A																															
Dielectric VAC (45 -65 Hz) or VDC	1.4 kV _{RMS} /1min. or 1.95 kVDC/1min.	N/A																															
Impulse voltage	± 2.55 kVp	± 1 kVp																															



Table 1-4. Specifications (continued)

Property	Characteristic/Value		
	Test	Common Mode	Normal Mode
Electromagnetic compatibility Conducted transients	Voltage/current surge (1.2/50 μ S to 8/20 μ S) (IEC 61000-4-5, EN 61000-4-5)	± 2 kVp	± 1 kVp
	Fast transient bursts (IEC 61000-4-4, EN 61000-4-4)	± 2 kVp	N/A
	Damped oscillatory wave, 0.1 MHz and 1 MHz (IEC 61000-4-12, EN 61000-4-12)	± 1 kVp	$\pm 0, 5$ kVp
	Ring wave (IEC 61000-4-12, EN 61000-4-12)	± 2 kVp	± 1 kVp
	Electrostatic discharge (IEC 61000-4-2, EN 61000-4-2)	Contact: ± 6 kV Air: ± 8 kV	
Magnetic and electro-magnetic fields			
Power frequency magnetic field (IEC 61000-4-8, EN 61000-4-8)	Continuous: 30 A/m (rms) Short duration: 300 A/m (rms)		
Pulse magnetic field (IEC 61000-4-9, EN 61000-4-9)	Peak value: 300 A/m		
Damped oscillatory magnetic field, 0.1 MHz and 1 MHz (IEC 61000-4-10, EN 61000-4-10)	Peak value: 30 A/m		
Radiated radio-frequency electromagnetic field, 80 MHz to 1GHz (IEC 61000-4-3)	Unmodulated rms: 10 V/m Amplitude modulated: 80% AM (1 kHz)		
Radiated radio-frequency field, 900 ± 5 MHz (ENV 50204)	Unmodulated rms: 10 V/m Pulse modulated: Duty cycle 50% Rep. cycle 200 Hz		
Radio-frequency common mode, amplitude modulated, 0.15 MHz to 80 MHz (IEC 61000-4-6)	Unmodulated rms: 10 V/rms Amplitude modulated: 80% AM (1 kHz) Source impedance: 150 Ω		

Table 1-4. Specifications *(continued)*

Property	Characteristic/Value
Emission test RF radiated fields, 30 MHz to 1000 MHz (EN 55011)	Class A
CE Mark Declaration	This product, when installed in a Symphony enclosure, complies with the following Directives/Standards requested for CE marking:
EMC 89/336/EEC	EN50081-2 Generic Emission Standard - Part 2: Industrial Environment EN50082-2 Generic Immunity Standard - Part 2: Industrial Environment
Low Voltage Directive 73/23/EEC	EN 61010-1 Safety Requirements for Electrical Equipment for Measurement, Control and Laboratory Use - Part 1: General Requirements
Certifications	
Canadian Standards Association (CSA)	Certified for use as process control equipment in an ordinary (nonhazardous) location.
Factory Mutual (FM) (pending)	Approval for the following categories. Nonincendive for: Class I, Division 2, Groups A,B,C,D Class II, Division 2, Groups F,G

SPECIFICATIONS SUBJECT TO CHANGE WITHOUT NOTICE.





Introduction

This section explains the inputs and input circuitry, control logic, logic power and connections for the IMDSI13, IMDSI14, and IMDSI22 Digital Input Modules. The DSI module is a digital input interface to Harmony controller. These controllers provide the control functions. A controller communicates with its I/O modules on an I/O expander bus as shown in Figure 1-1. Each I/O module on the I/O expander bus has a unique address set by address dipswitch S1 (Refer to *Input Circuits*).

Module Description

The digital input module consists of a single printed circuit board that occupies one slot in a module mounting unit. It monitors two separate groups of eight digital inputs. Twelve inputs are isolated from each other; the remaining two pairs share common positive input lines.

Two captive screws on the module faceplate secure it to the module mounting unit. Sixteen front panel LED status indicators (group A and group B) display the input status and provide aid in system test and diagnosis.

The digital input module has three card edge connectors for external signals and power (P1, P2 and P3). P1 connects to common (ground) and +5 VDC power. P2 connects the module to the I/O expander bus to communicate with a controller. P3 inputs the digital signals using a cable connected to a termination unit. The terminal blocks (physical connection points) for field wiring are on the termination unit.

Inputs

Digital field inputs are voltages of 120 VAC, 24 VDC, 48 VDC, or 125 VDC. These voltages indicate an energized (on) field device; a zero volt input indicates a de-energized (off) field device. The DSI modules have a fixed input debounce filter for



DC inputs to allow for contact debounce time (17 millisecond response time).

The IMDSI13 (24 VDC), the IMDSI14 (48 VDC), modules have fixed configurations and do not require any jumper selections. The IMDSI22 (120 VAC, 24VDC, 48VDC, or 125 VDC) module has jumpers to select the working voltage. Refer to [Section 3](#) for an explanation of the jumper connections.

NOTE: Due to the number of pins on the P3 connector, 12 inputs are separate while the remaining two pairs share input terminals. The positive (+) side of point seven and eight are tied together in each group (refer to [Table 5-1](#)). These points must use the same contact voltage (120 VAC, 24 VDC, 48 VDC, or 125 VDC) set by the jumpers on the IMDSI22 module, or according to the relevant modules working voltage.

Input Circuits

Figure 2-1 is a block diagram illustrating signal flow through the module. The input isolation block consists of current limiters and optocouplers to isolate the 16 field inputs from the module circuitry. The input circuits provide 1500 VDC isolation between input and logic circuitry and other input channels. For further information on specifications refer to [Table 1-4](#).

Digital input high impedance provides additional (passive) protection from high energy transients of field digital inputs.

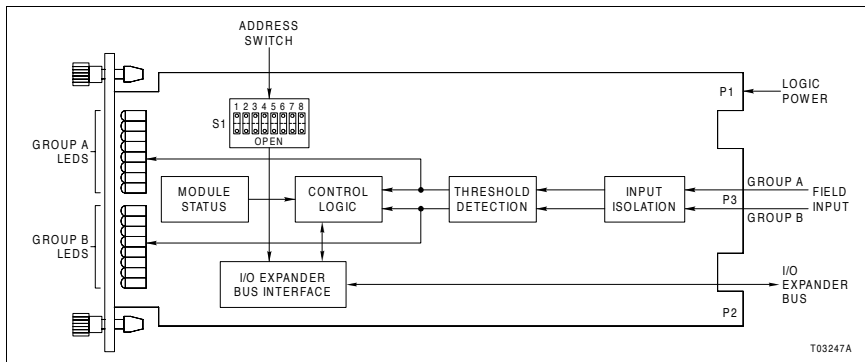

Figure 2-1. Digital Input Module Block Diagram

Input signal path and low isolation capacitance allow protection against fast transient-burst disturbance.

The threshold detection block circuits test the input voltage to determine if it is at the proper voltage level to indicate an (on) or (off) state. The output of this comparator is sent to a read buffer in the control logic block. If an input is energized, it also causes a corresponding input status LED on the front panel to light.

The control logic block consists of buffers that hold the input and status byte values. The I/O expander bus interface allows the controller to read these bytes.

Input Circuit Description

When an input signal is present at the proper voltage level, a zener diode conducts (turns on) to cause current flow through an optocoupler. Configurable jumpers (on IMDSI22) or fixed resistors (on IMDSI13, IMDSI14 modules) select the turn-on threshold and input voltage.

The optocoupler output causes a comparator output to go low. This lights a corresponding status LED on the module front panel to indicate an energized input. The I/O expander bus interface transmits a logic one to the controller on the I/O expander bus. When no input signal is present, no current flows through the optocoupler. The front panel LED does not light and the DSI module transmits a logic zero on the I/O expander bus. Figure 2-2 shows the digital input circuit.

NOTE: The components inside the dashed boxes in Figure 2-2 are mounted only on the module versions stated in the note.

Input Circuit Connections

The contact input signals connect to the 30-pin card edge connector (P3), shown in Figure 2-1, using a termination cable from a termination unit.

Control Logic

Function code 84 in the controller configuration accesses the DSI module on the I/O expander bus. It also allows the controller to automatically read point (input) data or status data from

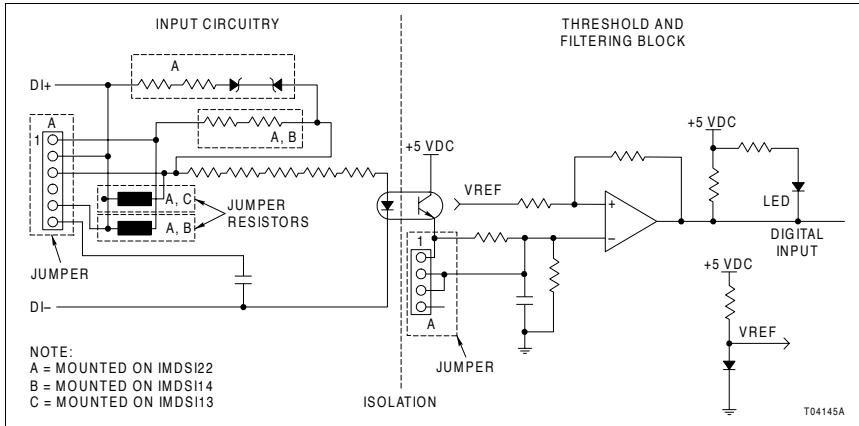

Figure 2-2. Digital Input Module Circuitry

the DSI module. This data is output by the buffer circuits (control logic) to the I/O expander bus interface (Fig. 2-1). The I/O address in function code 84 must be the same as the address set on address dipswitch (S1).

Point Data Byte

Point data is two eight-bit bytes. Each byte corresponds to group A or group B inputs. Each bit of data represents one input. The bit value reflects the state of that input, either open (logic zero) or closed (logic one).

Status Byte

The status byte ensures module integrity. It makes sure I/O expander bus communication and controller configuration are correct. The controller reads the status byte and compares it to an expected value. If a mismatch occurs, it flags the error and marks the point as bad quality.

Logic Power

Logic power (+5 VDC) drives the DSI module circuits. It connects through the 12-pin card edge connector (P1) shown in Figure 2-1.

I/O Expander Bus

The I/O expander bus is a high speed, synchronous, parallel bus. It provides a communication path between controller and I/O modules. The controller provides the control functions and the DSI module provides input to the controller. The P2 card edge connector of the DSI module and controller connect to the I/O expander bus.

The I/O expander bus is parallel signal lines located on the module mounting unit back plane. A 12-position dipshunt placed in a connection socket on the module mounting unit back plane connects the I/O expander bus to the controller and I/O modules. Cable assemblies can extend the I/O expander bus to six module mounting units.

A controller and its I/O modules form an individual subsystem within a process control unit (PCU). The I/O expander bus between controller and I/O module subsystems must be separated by leaving a dipshunt socket empty or not connecting the module mounting units with cables.

Universal I/O Expander Bus Interface

The DSI module uses a custom gate array to perform the I/O expander bus interface function. All the control logic and communication protocol are built into an integrated circuit. This integrated circuit provides the following functions:

- Address comparison and detection.
- Function code latching and decoding.
- Read strobe generation.
- Data line filtering of bus signals.
- On-board bus drivers.

Mounting Hardware

Harmony rack I/O modules and termination units mount in standard enclosures (CAB-01, CAB-04, CAB-12). The number of modules that can be mounted in a single cabinet varies.

An IEMMU11, IEMMU12, IEMMU21, or IEMMU22 Module Mounting Unit and an NFTP01 Field Termination Panel are used for module and termination unit mounting respectively



(Fig. 2-3). The mounting unit and termination panel both attach to the side rails in standard 483-millimeter (19-inch) enclosures. Front mount and rear mount module mounting unit versions are available to provide flexibility in enclosure mounting.

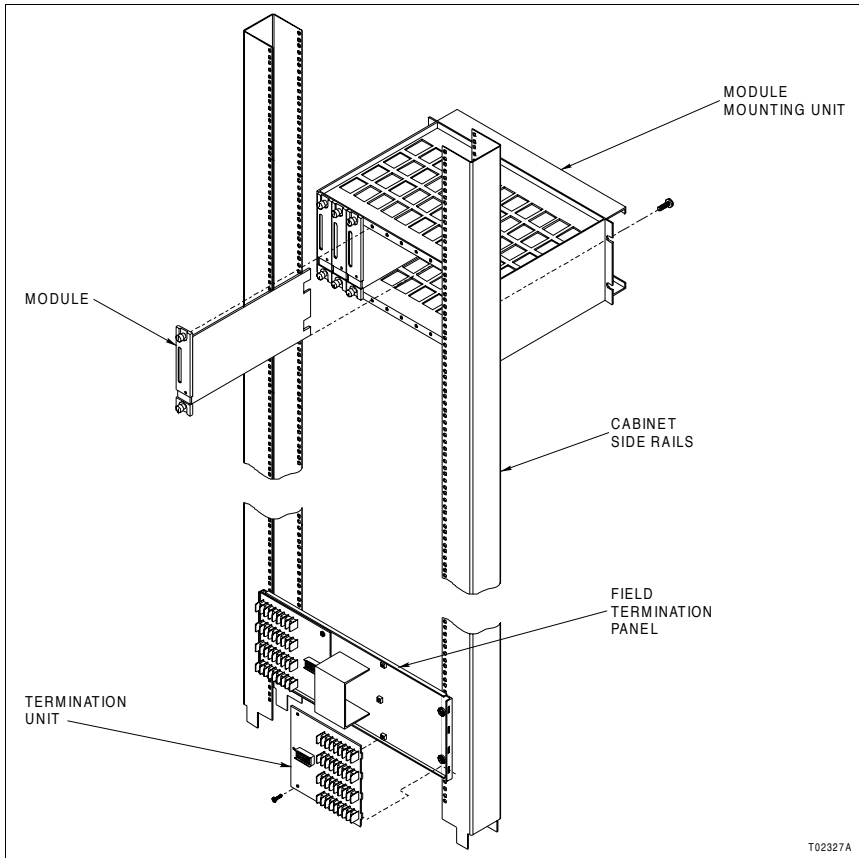

Figure 2-3. Mounting Hardware

A module mounting unit is required to mount and provide power to rack-mounted modules. The unit is for mounting controllers, I/O modules, and communication interface modules. The MMU backplane connects and routes:

- Controlway.
- I/O expander bus.
- Logic power to control, I/O, and interface modules.

The Controlway and I/O expander bus are internal cabinet, communication buses. Communication between rack controllers and communication interface modules is over Controlway.





Introduction

This section explains the procedures required to put the IMDSI13, IMDSI14, and IMDSI22 Digital Input Modules into operation. It includes instructions on setting the address selection switch, digital input jumper settings, termination configuration and physical installation. Information is also provided on wiring connections and cabling, fusing and preoperating adjustments. **Do not** proceed with operation until you read, understand and complete the steps in the order in which they appear.

Special Handling

NOTE: Always use the approved field static kit (part number 1948385A1), consisting of two wrist straps, ground cord assembly, alligator clip, and static dissipating work surface when working with static sensitive devices. The kit is designed to connect the technician and the static dissipating work surface to the same ground point to prevent damage to the static sensitive devices by electrostatic discharge.

Use the static grounding wrist strap when installing and removing modules. Static discharge may damage static sensitive devices on modules in a cabinet. Use grounded equipment and static safe practices when working with static sensitive devices.

1. **Use Static Shielding Bag.** Keep the module in its static shielding bag until you are ready to install it in the system. Save the bag for future use.
2. **Ground Bags before Opening.** Before opening a bag containing an assembly with static sensitive devices, touch it to the equipment housing or ground to equalize charges.
3. **Avoid Touching Circuitry.** Handle assemblies by the edges; avoid touching the circuitry.



4. **Avoid Partial Connection of Static Sensitive Devices.** Verify that all devices connected to the modules are properly grounded before using them.
5. **Ground Test Equipment.**
6. **Use an Antistatic Field Service Vacuum.** Remove dust from the cards if necessary.
7. **Use a Grounded Wrist Strap.** Connect the wrist strap to the appropriate grounding plug.
8. **Do Not Use Lead Pencils to Set Dipswitches.** To avoid contamination of switch contacts that can result in unnecessary circuit board malfunction, do not use a lead pencil to set a dipswitch.

Unpacking and Inspection

1. Examine the hardware immediately to verify it has not been damaged in transit.
2. Notify the nearest sales office of any such damage.
3. File a claim for any damage with the transportation company that handled the shipment.
4. Use the original packing material and container to store the hardware.
5. Store the hardware in an environment of good air quality, free from temperature and moisture extremes.

Setup and Physical Installation

Prior to installation, set the module S1 address switch and install jumpers to configure the digital inputs. Configure the termination unit to accept the field device signals. Refer to [Appendix A](#) for configuration information.

Address Selection Switch (S1)

The DSI module can have one of 64 addresses (address 0 to 63) on the I/O expander bus. This address uniquely identifies the I/O module to the controller and must be the same as the

address set in the controller configuration (function code 84, specification S1).

The address is set by an eight position address dipswitch (S1), shown in Figure 3-1. The six right switch positions (three through eight) of S1 set the six bit DSI module address. Positions one and two are not used and must remain in the closed settings.

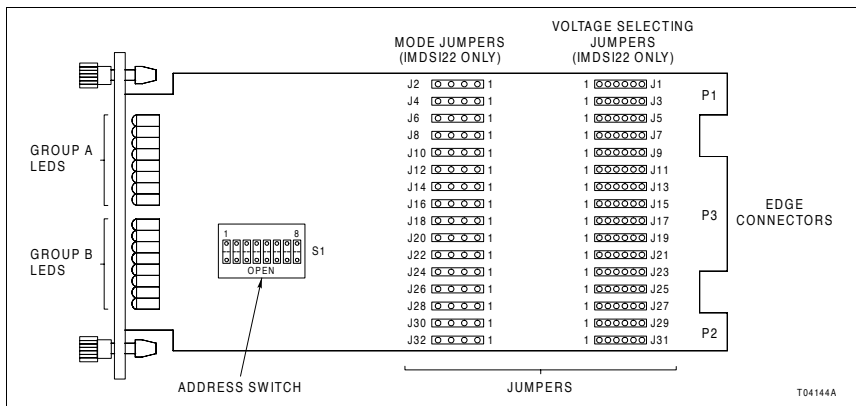

Figure 3-1. Module Layout

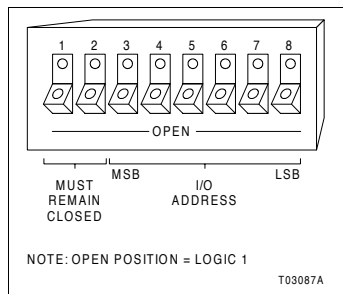

Figure 3-2. Address Select Switch S1 Settings



Table 3-1. S1 Address Switch Settings Examples

ADDR	MSB						LSB
	3	4	5	6	7	8	
5	0	0	0	1	0	1	
15	0	0	1	1	1	1	
32	1	0	0	0	0	0	

NOTE: 1 = OPEN; 0 = CLOSED

Digital Input Jumper Settings

The IMDSI13, IMDSI14, and IMDSI15 modules have fixed configurations; no jumper settings are required. The IMDSI22 (120 VAC, 24 VDC, 48 VDC, 125 VDC) module requires jumper settings for both the working voltage and the correct DC or AC mode selections.

To set the jumpers for the IMDSI22 module:

1. Refer to Table 3-2 and start with input A1, jumper J1. Move to the right and locate the desired working voltage. Note the jumper/pin position. Position the J1 jumper strap in that position.
2. Refer to Table 3-3 and start with input A1, jumper J2. Move to the right and locate the correct digital input mode and note the jumper/pin position. Position the J2 jumper strap in that position.
3. Repeat Steps 1 and 2 until the jumpers are set for group A and group B inputs.

Table 3-2. Working Voltage Settings (IMDSI22)

Input	Jumper	120 VAC	24 VDC	48 VDC	125 VDC
A1	J1	5-6	2-3	1-2	3-4
A2	J3	5-6	2-3	1-2	3-4
A3	J5	5-6	2-3	1-2	3-4
A4	J7	5-6	2-3	1-2	3-4
A5	J9	5-6	2-3	1-2	3-4
A6	J11	5-6	2-3	1-2	3-4
A7	J13	5-6	2-3	1-2	3-4
A8	J15	5-6	2-3	1-2	3-4

Table 3-2. Working Voltage Settings (IMDSI22) (continued)

Input	Jumper	120 VAC	24 VDC	48 VDC	125 VDC
B1	J17	5-6	2-3	1-2	3-4
B2	J19	5-6	2-3	1-2	3-4
B3	J21	5-6	2-3	1-2	3-4
B4	J23	5-6	2-3	1-2	3-4
B5	J25	5-6	2-3	1-2	3-4
B6	J27	5-6	2-3	1-2	3-4
B7	J29	5-6	2-3	1-2	3-4
B8	J31	5-6	2-3	1-2	3-4

Table 3-3. Mode Settings (IMDSI22)

Input	Jumper	AC Mode	DC Mode
A1	J2	1-2	3-4
A2	J4	1-2	3-4
A3	J6	1-2	3-4
A4	J8	1-2	3-4
A5	J10	1-2	3-4
A6	J12	1-2	3-4
A7	J14	1-2	3-4
A-8	J16	1-2	3-4
B1	J18	1-2	3-4
B2	J20	1-2	3-4
B3	J22	1-2	3-4
B4	J24	1-2	3-4
B5	J26	1-2	3-4
B6	J28	1-2	3-4
B7	J30	1-2	3-4
B8	J32	1-2	3-4

Termination Configuration

A termination unit connects the field device wiring to the system. The terminal blocks (connection points) are located on the termination unit.



Configuration of the termination unit is required to accept the digital field inputs sent to the DSI module. Refer to [Appendix A](#) for additional information.

Physical Installation

NOTE: This installation section provides instructions pertaining to the physical installation of the digital input module only. For complete cable and termination information, refer to the applicable instruction.

The DSI module inserts into a standard module mounting unit and occupies one slot. To install:

1. Verify the slot assignment of the module.

WARNING

Disconnect power before installing dipshunts on the module mounting unit backplane. Failure to do so will result in contact with cabinet areas that could cause severe or fatal shock.

2. Verify that a dipshunt is in the I/O expander bus socket on the module mounting unit backplane between the I/O module and controller.
3. For termination units, connect the hooded end of the termination cable from the termination unit to the module mounting unit backplane. To do this, insert the connector into the backplane slot in the same slot as the one assigned to the DSI module. The latches should snap securely into place.
4. Align the DSI module with the guide rails in the module mounting unit. Gently slide the module in until the front panel is flush with the top and bottom of the module mounting unit frame and the module is seated in the cable to the termination unit.
5. Push and turn the two captive retaining screws on the module faceplate one half turn to the latched position. It is latched when the slots on the screws are vertical and the open ends face the center of the module.

Wiring Connections and Cabling

The DSI module has three card edge connectors to supply logic power, establish I/O expander bus communication and provide digital inputs (P1, P2, P3 respectively).

Wiring

Installing the module in the module mounting unit connects the DSI module to the logic power (+5 VDC), necessary to drive the circuitry, at P1. It also connects P2 to the I/O expander bus for communication with the controller. P1 and P2 connections require no additional wiring or cabling.

NOTE: Install a dipshunt on the backplane of the module mounting unit to connect the I/O expander bus between the DSI module and controller. Locate the modules so the bus can connect the modules or they will not communicate.

Cable Connections

The DSI digital input module uses an NTDI01 termination unit for termination. Refer to Figure 3-3 to determine the cable to use with the NTDI01 termination unit.

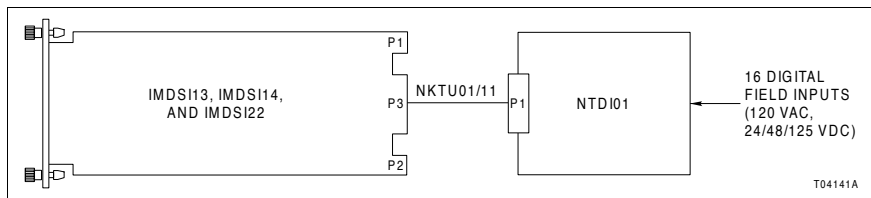

Figure 3-3. Cable Connections and Termination





Introduction

This section explains the front panel indicators and startup procedures for the IMDSI13, IMDSI14, and IMDSI22 Digital Input Modules.

Indicators

The DSI modules have point (input) status LED indicators on the front panel to aid in system test and diagnosis. There are 16 LEDs divided into two groups of eight (group A and group B). The location of the LEDs is shown in Figure 4-1. Each indicator represents a digital input. A red LED indicates an energized input. A blank LED indicates a nonenergized input.

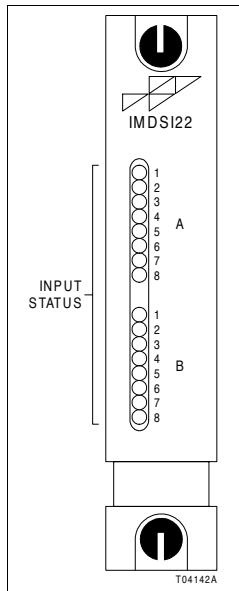

Figure 4-1. Front Panel View



Startup Procedures

The controller controls the startup of the DSI modules and is fully automatic. Function code 84 in the controller configuration enables the DSI modules. Specification S1 of function code 84 is the I/O module address. It must be the same as the address set on the address dipswitch (S1).



Introduction

This section explains the error indications and corrective actions for the IMDSI13, IMDSI14, and IMDSI22 Digital Input Modules.

Error Indications and Corrective Action

Obtain the status of the DSI module by checking the controller for good quality on its input blocks. Use any human system interface to do this.

NOTE: Observe the DSI module front panel input status LED indicators. If there are no LEDs lit, this may indicate a faulty DSI module (an input must be energized to light an LED). Check the controller for bad quality on its input blocks.

Controller Errors

The address set on address switch S1 and in the controller configuration must be the same. The controller generates a *MISSING SLAVE MODULE* error if they do not match. Verify that the address set on switch S1 is the same as the address in function code 84, specification S1. If not:

1. Remove the module and change the setting of S1 to correspond with the module configuration. Refer to **Setup and Physical Installation** in Section 3 for the procedures to set an address and to install a digital input module.

- or -

2. Modify the address in the module configuration function code 84, (specification S1) to correspond with the address set on S1. Use a human system interface to modify the configuration. For procedures on how to modify a function code specification, refer to the instruction for the human system interface being used.

**WARNING**

Disconnect power before installing dipshunts on the module mounting unit backplane. Failure to do so will result in contact with cabinet areas that could cause severe or fatal shock.

The controller generates a *MISSING SLAVE MODULE* error if the I/O expander bus is not connected between the digital input module and the controller. Verify the bus connection on the module mounting unit backplane.

NOTE: If function code 84, specification S3 is set to zero, the controller will trip when the DSI module fails. Changing specification S3 to a one will allow the controller to continue to operate when a digital input module fails.

If the digital input module is faulty, replace it with a new one. Refer to [Section 7](#) for procedures to replace a DSI module.

Module Pin Connections

The digital input module has three connection points for external signals and power (P1, P2 and P3). Tables [5-1](#), [5-2](#), and [5-3](#) show the pin connections.

Table 5-1. P3 Input Signal Pin Connections

Digital Input	Group A		Group B		
	Pin (+)	Pin (-)	Digital Input	Pin (+)	Pin (-)
1	A	1	1	K	9
2	B	2	2	L	10
3	C	3	3	M	11
4	D	4	4	N	12
5	E	5	5	P	13
6	F	6	6	R	14
7	H ¹	7	7	S ¹	15
8	H	J	8	S	8

NOTE:

1. Shared pin (inputs 7 and 8).

Table 5-2. P1 Power Pin Connections

Pin (P1)	Connection
1	+5 VDC
2	+5 VDC
3	NC
4	NC
5	Common
6	Common
7	NC
8	NC
9	NC
10	NC
11	NC
12	NC

NOTE: NC = Not connected

Table 5-3. P2 Expander Bus Connections

Pin (P2)	Signal
1	Data 1
2	Data 0
3	Data 3
4	Data 2
5	Data 5
6	Data 4
7	Data 7
8	Data 6
9	Clock
10	Sync
11	NC
12	NC

NOTE: NC = Not connected





Introduction

The reliability of any stand-alone product or control system is affected by the maintenance of the equipment. It is recommended that all equipment users practice a preventive maintenance program that will keep the equipment operating at an optimum level.

This section presents procedures that the customer should be able to perform on site. These preventive maintenance procedures should be used as a guideline to assist in establishing good preventive maintenance practices.

Personnel performing preventive maintenance should meet the following qualifications.

- Maintenance personnel should be qualified electrical technicians or engineers that know the proper use of test equipment.
- Maintenance personnel should be familiar with the module mounting unit, have experience working with process control systems, and know what precautions to take when working on live AC and/or DC systems.

Preventive Maintenance Schedule

Table 6-1 is the preventive maintenance schedule for the digital input module. The table lists the preventive maintenance tasks in groups according to their specified maintenance interval. Instructions for tasks that require further explanation are covered under *Preventive Maintenance Procedures*.

NOTE: The preventive maintenance schedule is for general purposes only. Different applications may require special attention.



Equipment and Tools Required

The tools and equipment required for maintenance procedures are:

- Antistatic vacuum.
- Screwdriver (medium length).
- Isopropyl alcohol (99.5 percent electronic grade).
- Distilled water.
- Compressed air.
- Foam-tipped swabs.
- Lint-free cloths.
- Nonabrasive eraser.

Table 6-1. Preventive Maintenance Schedule

Task	Frequency
Check cabinet, module mounting unit backplane assembly, digital input module and termination device for dust. Clean as necessary using an antistatic vacuum. If circuit board cleaning is necessary, refer to procedure.	Every six months or during plant shut-down, whichever occurs first.
Check all signal, power and ground connections that are associated with the digital input module. Verify that they are secure. Refer to procedure.	

Preventive Maintenance Procedures

This section covers tasks from Table 6-1 that require specific instructions or further explanation.

- Cleaning printed circuit boards and edge connectors.
- Checking signal, power and ground connections.

Printed Circuit Board Cleaning

There are several circuit board cleaning procedures in this section. These procedures cover circuit board cleaning and washing, cleaning edge connectors and circuit board laminate between edge connectors. Use the procedures that meet the needs of each circuit board. Remove all dust, dirt, oil, corrosion or any other contaminant from the circuit board.

Do all cleaning and handling of the printed circuit boards at static safe work stations. Always observe the steps in [Section 3](#) when handling printed circuit boards.

WARNING **Never clean electrical parts or components with live power present. Doing so exposes you to an electrical shock hazard.**

Wear eye protection whenever working with cleaning solvents. When removing solvents from printed circuit boards using compressed air, injury to the eyes could result from splashing solvent as it is removed from the printed circuit board.

General Cleaning and Washing

If the printed circuit board needs minor cleaning, remove dust and residue from the printed circuit board surface using clean, dry, filtered compressed air or an antistatic field service vacuum cleaner.

To wash the printed circuit board:

1. Clean the printed circuit board by spraying or wiping it with isopropyl alcohol (99.5% electronic grade). Use a foam-tipped swab to wipe the circuit board.
2. Remove excess solvent by using compressed air to blow it free of the circuit board.

Edge Connector Cleaning

1. Use a solvent mixture of 80% isopropyl alcohol (99.5% electronic grade) and 20% distilled water.
2. Soak a lint-free cloth with the solvent mixture.
3. Work the cloth back and forth parallel to the edge connector contacts.
4. Repeat with a clean cloth that is soaked with the solvent mixture.
5. Dry the edge connector contact area by wiping with a clean lint-free cloth.

To clean tarnished or deeply stained edge connector contacts:

1. Use a nonabrasive eraser to remove tarnish or stains. Fiberglass or nylon burnishing brushes may also be used.
2. Minimize electrostatic discharge by using the 80/20 isopropyl alcohol/water solution during burnishing.



3. Do not use excessive force while burnishing. Use only enough force to shine the contact surface. Inspect the edge connector after cleaning to assure no loss of contact surface.
4. Wipe clean with a lint-free cloth.

Checking Connections

NOTE: Power to the cabinet should be off while performing this preventive maintenance task.

WARNING

There are exposed AC and DC connections inside the cabinet. These exposed electrical connections present a shock hazard that can cause injury or death.

If input or output circuits are a shock hazard after disconnecting system power at the power entry panel, then the door of the cabinet containing these externally powered circuits must be marked with a warning stating that multiple power sources exist.

Check all signal wiring, power and ground connections within the cabinet to verify their integrity. When checking connections, always turn a screw, nut or other fastening device in the direction to tighten only. If the connection is loose, it will be tightened. If the connection is tight, the tightening action will verify that it is secure. There must not be any motion done to loosen the connection.

1. Verify that all power connections within the cabinet are secure.
2. Verify that all field wiring connections to the termination unit are secure.



Introduction

This section explains the replacement procedures for a IMDSI13, IMDSI14 and IMDSI22 Digital Input Module. There are no special tools required to replace a DSI module.

Module Repair and Replacement

If the DSI module is faulty, replace it with a new one. **Do not** try to repair the module; replacing components may affect the module performance. System power may remain applied during module removal and replacement. To replace a module:

1. Push and turn the two front panel captive retaining screws one half turn to unlatch the module. It is unlatched when the slots on the screws are vertical and the open end of the slots face away from the module.
2. Gently slide the module out of the module mounting unit.
3. Configure the replacement module switch and jumper settings. Ensure they are the same as the original module.
4. In the same slot assignment as the original module, align the replacement module with the guide rails in the module mounting unit. Gently slide it in until the front panel is flush with the top and bottom of the module mounting unit frame.
5. Push and turn the two captive retaining screws on the module faceplate one half turn to the latched position. It is latched when the slots on the screws are vertical and the open ends face the center of the module.
6. Return to normal operation.





Introduction

The IMDSI13, IMDSI14, and IMDSI22 modules use an NTDI01 termination unit. Dipshunts on the termination unit configure the digital inputs. The digital input module accepts inputs of 120 VAC, 24 VDC, 48 VDC, and 125 VDC, depending on the module selected.

Figure A-1 shows the NTDI01 dipshunt without strapping, and the digital signal path from the field device (contact) to the DSI module for a termination unit application. Refer to Table A-1 to determine the dipshunt strapping to configure the application. Figure A-2 shows the terminal assignments for the digital input signals. Refer to this figure when connecting field wiring to the NTDI01 termination unit.

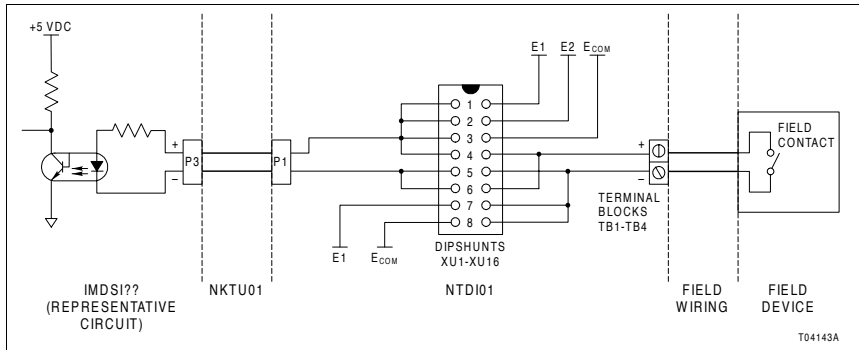

Figure A-1. NTDI01 Dipshunt



Table A-1. NTDI01 Dipshunt Configuration

Application/Signal Type	Dipshunt Configuration
Field powered contact	<div style="display: flex; justify-content: space-around;"> <div style="text-align: center;"> <p>XU1-XU16</p> </div> <div style="text-align: center;"> <p>XU17</p> <p>T03099A</p> </div> </div>
System powered from E1, 24 VDC, 48 VDC, 125 VDC, 120 VAC	<div style="display: flex; justify-content: space-around;"> <div style="text-align: center;"> <p>XU1-XU16</p> </div> <div style="text-align: center;"> <p>XU17</p> <p>T03100A</p> </div> </div>
System powered from E2, 24 VDC, 48 VDC, 125 VDC, 120 VAC	<div style="display: flex; justify-content: space-around;"> <div style="text-align: center;"> <p>XU1-XU16</p> </div> <div style="text-align: center;"> <p>XU17</p> <p>T03101A</p> </div> </div>

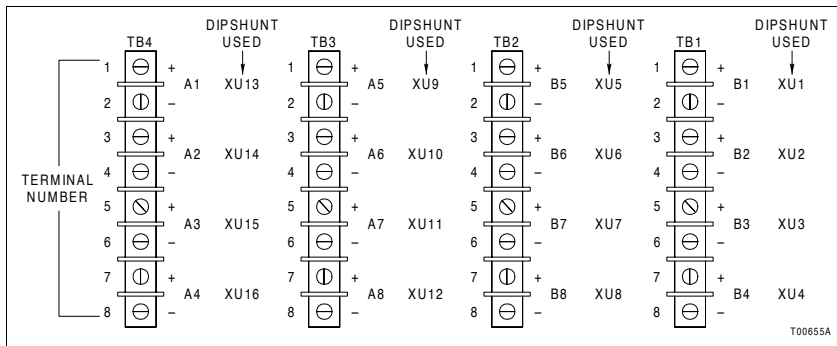

Figure A-2. NTDI01 Terminal Assignments



<p style="text-align: center;">A</p> <p>AC/DC mode jumper settings 3-4</p> <p>Address switch (S1)..... 3-3, 5-1</p> <p style="text-align: center;">B</p> <p>Block diagram, circuitry..... 2-2</p> <p style="text-align: center;">C</p> <p>Cable connections 3-7</p> <p>Checking connections 6-4</p> <p>Cleaning</p> <p> Edge connectors 6-3</p> <p> Printed circuit boards 6-2</p> <p>Communication levels..... 1-1</p> <p>Control logic..... 2-1, 2-3</p> <p>Conventions, document 1-3</p> <p style="text-align: center;">D</p> <p>DC/AC mode jumper settings 3-4</p> <p>Digital inputs 1-5, 2-1</p> <p>Dipshunt3-6, A-1</p> <p style="text-align: center;">E</p> <p>Electromagnetic compatibility 1-6</p> <p>Enclosures 2-5</p> <p>Errors</p> <p> Controller 5-1</p> <p> Indications..... 5-1</p> <p> Missing slave module 5-1</p> <p style="text-align: center;">F</p> <p>FC842-3, 3-3, 5-1, 5-2</p> <p>Field inputs 2-2</p> <p>Field static kit..... 3-1</p> <p>Field wiring 2-1</p> <p>FTP2-5</p>	<p style="text-align: center;">G</p> <p>Glossary 1-3</p> <p style="text-align: center;">I</p> <p>I/O expander bus.....2-5</p> <p>I/O expander bus interface.....2-5</p> <p>Input circuit connections.....2-3</p> <p>Input circuitry.....2-1, 2-2</p> <p>Installation</p> <p> Module3-6</p> <p> Termination devices3-6</p> <p>Instruction content 1-1</p> <p>Intended user 1-1</p> <p style="text-align: center;">J</p> <p>Jumper settings.....3-4</p> <p style="text-align: center;">L</p> <p>Logic power.....2-1, 2-4</p> <p style="text-align: center;">M</p> <p>Maintenance.....6-1</p> <p> Schedule6-1</p> <p> Tools required6-2</p> <p>Module description2-1</p> <p>Module mounting unit.....2-5</p> <p>Module replacement.....7-1</p> <p style="text-align: center;">N</p> <p>Nomenclature.....1-4</p> <p>NTDI01 termination unit 3-7, A-1</p> <p style="text-align: center;">O</p> <p>Overview 1-1</p>
---	--



Index (continued)

P	S
P1 connector.....2-1, 5-2	S1 address switch 3-2, 5-1
P2 connector.....2-1, 5-2	Special handling 3-1
P3 connector.....2-1, 5-2	Specifications 1-4
Pin connections.....5-2	Status byte..... 2-4
Point data byte 2-4	
Preventive maintenance	T
Schedule 6-1	Termination unit (TU).....3-5, A-1
Tools and equipment..... 6-2	
	U
R	Unpacking and inspection 3-2
Reference documents 1-4	
Replacement, module 7-1	W
	Wiring connections and cabling..... 3-6
	Working voltage jumper settings 3-4

*For the latest information on ABB and Year 2000 Product Compatibility
Visit us on the World Wide Web at <http://www.abb.com>*

Our worldwide staff of professionals is ready to meet *your* needs for process automation.
For the location nearest you, please contact the appropriate regional office.

Americas

29801 Euclid Avenue
Wickliffe, Ohio USA 44092
Telephone 1-440-585-8500
Telefax 1-440-585-8756

Asia/Pacific

539 Yishun Industrial Park A
Singapore 768740
Telephone 65-756-7655
Telefax 65-756-7309

Germany

Industriestrasse 28
D-65760 Eschborn
Germany
Telephone 49-6196-800-0
Telefax 49-6196-800-1119

Europe, Africa, Middle East

Via Puccini 2
16154 Genoa, Italy
Telephone 39-010-6584-943
Telefax 39-010-6584-941

