

Technical Information

ExperionPKS C300 Controller Capacity



EP03-300-511

[Keywords]

July 2019, Version 1

Revision History

Revision	Date	Description
1	July 16, 2019	Initial version – R511 release

Table of Contents

1.0 Product Introduction 4

 1.1 Experion System..... 4

 1.2 Architecture Overview..... 4

 1.3 Experion Controller Overview 5

2.0 Control Capacity and Performance..... 6

 2.1 Controller Definitions..... 6

 2.2 Control Network Capacity 7

 2.3 C300 Capacity and Performance 8

2.3.1 C300 Configuration Options 8

2.3.2 C300 Redundancy.....10

2.3.3 C300 Communication Performance.....10

2.3.4 C300 Processing and Memory Capacity Model14

2.3.5 C300 Memory17

2.3.6 C300 CEE Block Processing & Memory Usage Models17

2.3.7 IOLIM Communication Specifications20

2.3.8 C300-20 and C300-50 Functional Comparison.....21

3.0 Engineering Tools Performance Specifications..... 22

 3.1 Terms..... 22

 3.2 Tools Performance Specifications..... 23

4.0 C300 I/O Capacities..... 25

 4.1 IO UNIT Definition Table..... 25

1.0 Product Introduction

1.1 Experion System

The Experion® Process Knowledge System (PKS) is Honeywell’s unified control system for process, business, and asset management that helps industrial manufacturers increase their profitability and productivity. Experion takes customers well beyond distributed control system (DCS) functionality with an advanced automation platform solution and innovative application integration to improve business performance and peace of mind.

Refer to the “**Experion CEE-based Controllers and I/O Overview**” (document number **EP03-290-xxx**) for prerequisite information. This document is written with the expectation that the reader understands the information and concepts covered in the overview document.

1.2 Architecture Overview

The ExperionPKS platform comprises many different integrated hardware and software solutions depending upon the needs of the application. This pictured architecture is a representation of many of the possible nodes that can be utilized in the ExperionPKS architecture. Note that the architecture is highly scalable and not all nodes are necessary or required.

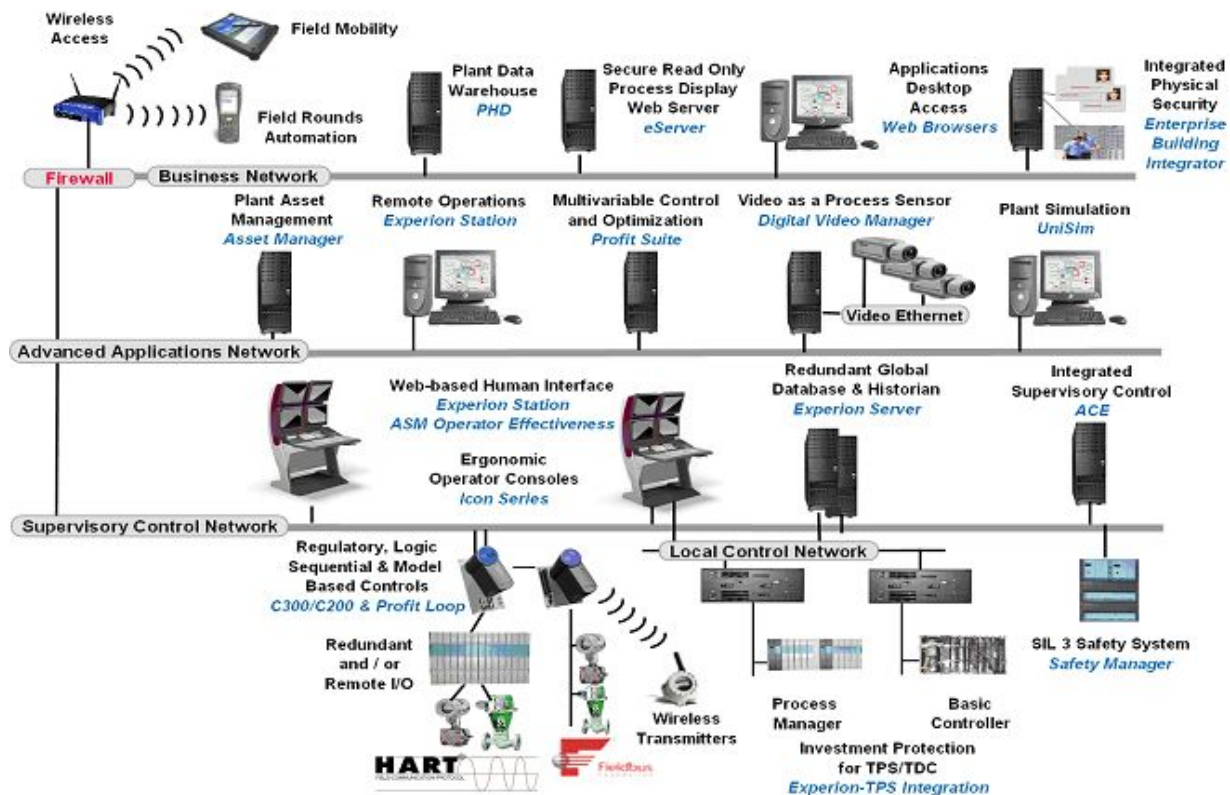

Figure 1 - Sample Experion Architecture

1.3 Experion Controller Overview

Honeywell offers multiple ExperionPKS controllers, ranging from embedded controller platforms with dedicated IO hardware to PC based control environments for supervisory control tasks or simulation. They all support one or more different network types to integrate the controllers with the ExperionPKS Server. They share a common Control Execution Environment (CEE) software infrastructure and a common builder tool. Together with the different station types, they form the ExperionPKS system. This specifications document provides details specifically related to the ExperionPKS C300 controller.

2.0 Control Capacity and Performance

2.1 Controller Definitions

In the following sections of this document the generic term “Controller” is used to reference various capacity and performance limits. Unless specifically noted differently, the following table defines what is meant by the term “Controller” when the specific controller type is not mentioned:

Non-Redundant Controllers:	Redundant Controllers:
1 C300 connected via FTE to a pair of CF9s (Yellow & Green) which are then connected to the L1 FTE Control Network	2 C300s configured as redundant pair connected via FTE to the same pair of CF9s (Yellow & Green) which are then connected to the L1 FTE Control Network
1 SIM-C300 configured in an SCE computer and connected to the simulation network ¹	
Note 1 SIM-C300 also count against Peer-Peer limits when it is configured for P2P communications with “On-line” controllers.	

2.2 Control Network Capacity

The following Table specifies FTE network capacity limits.

FTE	Capacity
Supervisory Networks per Experion Server:	1 redundant network serviced by 1 or more redundant or non-redundant EPKS Servers up to the max FTE Nodes allowed per FTE Community ^{[1]-2}
Maximum Number of Nodes allowed:	330 FTE Nodes per FTE Community ^{[1]-1}
Ethernet (non-FTE) Connections	200
Controllers per Server	Up to 60 Redundant or Non-Redundant ^{[1]-3,4}
Foundation Fieldbus Interface (FIM2/FIM4/FIM8)	Supported, see FOUNDATION™ Fieldbus Performance Limits
Transmission Rate	100 Mbits/sec 10 Mbits/sec for FTEBs

Notes [1] for FTE Ethernet:

1. When any FTEB or C300-20ms is present in the FTE Community, or if EtherNet/IP™ (EIP) is being deployed by one or more C300s in the FTE Community, the limit is 200 FTE Nodes.
2. SCADA connected PLCs can still be connected via ControlNet/PCIC when C200s, C200Es, or C300s reside on the FTE Supervisory Control Network.
3. SCADA PLCs do not count as “Controllers” against this limit on FTE
4. 60 controllers in any combination of CEE based Controllers (C200, C200E, C300, UOC, vUOC) and/or CDA-capable controllers (Safety Managers (Max 20), and/or PMD Field Controllers (Max 25), and/or EHPMs (defined in Section 16.3 EHPM Capacities)

Table 2.2

2.3 C300 Capacity and Performance

2.3.1 C300 Configuration Options

C300 Configuration Options		
	50 ms CEE	20 ms CEE ⁴
Control Networks Supported	FTE only ¹	FTE only ¹
Supported C300 Models ^{6,7}	CC-PCNT01 CC-PCNT02	CC-PCNT01 CC-PCNT02
Device Index Configuration	Between 1 and 510	Between 1 and 510
IOTA Size	6 inches	6 inches
Number of I/O Links Supported	2	2
I/O Link Speeds Available	375 Kbaud (PMIO Link) 750 Kbaud (Series C IO Link)	750 Kbaud (Series C IO Link) 375 Kbaud (PMIO Link) is not supported
Base Execution Periods Supported	50 ms	20 ms (optional) ⁴
Redundancy Supported	Yes	Yes
Remote – Non-Series C I/O Supported	Yes – PM I/O or Series A I/O ³	No – Only Series C I/O supported with limited capacities.
I/O Module Execution Period	50 ms	20 ms
Configurable Values for CM/SCM/RCM Execution Periods ⁵	50, 100, 200, 500, 1000, 2000, 5000, 10000, 20000, 300000, 60000 ms.	20, 40, 80, 200, 400, 800 ms. <i>CMs Only – SCM/RCM/MR not supported</i>
Configurable Values of Peer Update Rates (period). <i>Defines the period at which data is updated for all 'pull/get' requests for peer data required by all blocks within a CEE.</i>	100, 200, 500, 1000 ms.	100, 200, 500, 1000 ms.
C300 Time Source	SNTP, PTPv2	SNTP, PTPv2
SNTP Update Period	1 minute	1 minute
GPS Time Support ²	No	No
PTP Update Period	30 seconds	30 seconds
<p>Note 1 – Currently, every C300 must be connected to a Control Firewall</p> <p>Note 2 – A GPS connector is available on the IOTA, but it is not supported until a future release.</p> <p>Note 3 –C300 20ms supports only Series C I/O.</p> <p>Note 4 – Requires separately loaded Firmware Version and License. C300 20 ms CEE may ONLY be used for Honeywell Turbine Control Solution (TMCS) in R410.1.</p>		

Note 5- Slower execution periods are supported for Profit Controller Block only

Note 6- C300 controller CC-PCNT02 replaces CC-PCNT01 for new installations and field replacements.

Note 7- C300 controller must use CC-PCNT02 model with extended functionality firmware image for C300 extended functionalities (EIM, Profit Controller)

2.3.2 C300 Redundancy

C300 Redundancy Specifications		
	50 ms CEE	20 ms CEE ⁴
C300 Function Block Redundancy Configuration Selection:	"Module is Redundant"	"Module is Redundant"
Number of IOTAs used for Redundant C300	2	2
Redundant Device Index Configuration	Device Index = n, where n is an odd value Partner Device Index = n+1	Device Index = n, where n is an odd value Partner Device Index = n+1
Redundancy Cable Medium	Ethernet STP	Ethernet STP
Redundancy Cable Lengths	36, 48, 60, 84 inches	36, 48, 60, 84 inches
Control Processing Switchover Interruption Time ^{1,2}	500 ms	200 ms
Initial Synchronization Time (from Sync Start to Completion)	240 seconds	240 seconds
Maximum Elapsed Time Between Commanded Switchover and Completion of Initial Synchronization	500 seconds	500 seconds
Maximum Elapsed Time Between Switchover Due to Power Cycle of the Primary and Completion of Initial Synchronization	500 seconds	500 seconds
Maximum OPM Control Freeze time	20 seconds	20 seconds
Note 1 – Dual I/O Link failures may cause longer interruption times in the order of several seconds. Note 2- With Direct or Through EIM- C300-EtherNet/IP™ configuration, control processing switchover interruption time may go up to 2.5 seconds during C300 Switchover.		

2.3.3 C300 Communication Performance

C300 Communications Performance		
Definitions: <i>PPS = Average Parameters Per Second</i> <i>PPM = Average Parameters Per Minute</i> <i>EPS = Average Array Elements Per Second</i>	C300	
	50 ms CEE	20 ms CEE
Overall Data Access Performance		
Maximum Total Parameter Access Response Rate <i>(Includes all Server Data Requests, Console Station Data Requests, and peer communications including other ACEs, C200s, C300s, SIM-C200s, SIM-C300s, SIM-ACEs, and FIMs)</i> ¹³	2500 PPS	700 PPS
Display Data Access Capacity	50 ms CEE	20 ms CEE

C300 Communications Performance		
Maximum Total Subscribed Parameters per C300 <i>(Includes all Server Data Requests + Console Station Data Requests)</i> ¹³	4000	4000
Request/Response Data Access Performance	50 ms CEE	20 ms CEE
Max Request/Response Parameter Access Rate <i>(Includes all Slow Server Data Requests, e.g. Greater than 10 sec OPC data, Slow History, Data Writes, etc.)</i>	3000 PPM Read 1500 PPM Write	750 PPM Read 375 PPM Write
Peer-to-Peer Performance	50 ms CEE	20 ms CEE
Maximum Initiator Pull/Get Subscribe Rate to all target nodes. (incoming data) ⁷	1000 PPS	250 PPS
Maximum Target Publish Rate to Pull/Get Subscriptions from all initiator nodes. (outgoing data) ⁸	1000 PPS	250 PPS
Peer-to-Peer Subscription Capacity / Update Rate	50 ms CEE	20 ms CEE
Total Maximum C300 peer capacity per update rate choices	100 @ 100 ms 200 @ 200 ms 500 @ 500 ms 1000 @ 1 sec	25 @ 100 ms 50 @ 200 ms 125 @ 500 ms 250 @ 1 sec
Maximum C300 peer capacity for non-CEE parameter references (Includes peer references to SM, PMD FC, EHPM, and Server Point parameters and is included in the total limit for the row above)	500 parameters	NA
Push/Store Request Capacity	50 ms CEE	20 ms CEE
Maximum number of Push/Store Requests to all target nodes and local IOLink EEs, in progress simultaneously	800	800
Maximum number of Push/Store Requests initiated in a single CEE execution cycle	200	200
Push/Store Request Performance	50 ms CEE	20 ms CEE
Maximum Push/Store Request Rate to all target nodes and local IOLink EEs ²	50 PPS	12 PPS
Maximum Response Rate to Push/Store Requests from all initiator nodes ²	50 PPS	12 PPS
Whole Array Capacity	50 ms CEE	20 ms CEE
Max Array Size for Whole Array Transfer	8K bytes (1000 float64s)	8K bytes (1000 float64s)
Initiator's Max Whole Array Connection References	25	25
Responder's Max Whole Array Connections (from all peers using pub-sub)	15	15
Initiator's Max Whole Array Connection References (to all peers using request/response)	5	5

C300 Communications Performance		
Responder's Max Whole Array Connections (to all peers using request/response)	5	5
Peer-Peer Whole Array Transfer Performance	50 ms CEE	20 ms CEE
Max Initiator Whole Array Request Rate (to all peers)	2500 EPS	600 EPS
Max Target Node Response Rate to Whole Array Pull/Get Requests <i>(from all initiator nodes)</i>	1500 EPS	350 EPS
Initiator Whole Array Push/Store Rate	1000 EPS	250 EPS
Target Node Whole Array Response Rate to Push/Store Requests <i>(from all initiator nodes)</i>	1000 EPS	250 EPS
Peer-to-Peer Capacity	50 ms CEE	20 ms CEE
Peer Connection Units (PCUs) ^{2, 9} <i>(Number of remote CEEs that this C300 can initiate a peer connection with)</i>	30 ³ <i>(Includes total of all other UOC/UOC, ACEs, SIM-ACEs, C200s, C200Es, C300s, LIOMs, SIM-CXXXs, IOLIMs, Server Peers, SIMs, WDMs, and/or Primary FIMs)</i>	5 ³ <i>(Includes total of other UOC/UOC, ACEs, SIM-ACEs, C200s, C200Es, C300s, SIM-C200s, SIM-C200Es, SIM-C300s)</i>
Peer-to-Peer Capacity using Exchange FB	50 ms CEE	20 ms CEE
Maximum Number of REQUEST blocks per C300	32	Not Supported
Maximum Number of RESPONSE blocks per C300	32	Not Supported
Maximum Number of Target Devices for REQUEST blocks per C300 ⁴	8	Not Supported
Maximum Number of Remote Initiating Devices for RESPONSE block data per C300	8	Not Supported
Maximum Request Rate using Exchange blocks to all target nodes ¹¹	500 PPS	Not Supported
Maximum Response Rate to Exchange Requests from all initiator nodes ¹¹	500 PPS	Not Supported
PCDI Capacity and Performance	50 ms CEE	20 ms CEE
Maximum Number of Modbus TCP devices ^{5,10} <i>(represented by PCDI Master blocks)</i>	8	3
Maximum Number of Serial Modbus Devices per Gateway	16	3
Maximum Number of Serial Modbus Devices per C300 <i>(8 * 16 of above two specifications)</i>	128	3
Maximum Number of PCDI Request blocks assigned to a PCDI Master block	64	8

C300 Communications Performance		
Maximum Number of PCDI Request block messages per second – includes both Reads and Write ⁶ (maximum size 256 byte messages assumed)	250	30
Process Data Access (PDA) Capacity and Performance	50 ms CEE	20 ms CEE
Maximum number of PGM PDA connections per C300	4	Not Supported
Maximum number of Decentralized Periphery (DP) networks per C300	8	Not Supported
Maximum number of PIOMB blocks per C300 Controller ¹²	640 Decentralized Periphery (DP) devices	Not Supported
Maximum number of Process Data Collection (PDC) messages per second – includes both Reads and Write (maximum size 256 byte messages assumed)	2500 PDC messages per second	
<p>Note 2 – Exchange Peer-Peer does not count against this limit.</p> <p>Note 3 – There are 31 connections reserved for Peer-Peer in the C300. 1 connection is reserved for Internal C300 use-only, leaving 30 connections available for User P2P configurations.</p> <p>Note 4 – 1 DHRIO Module only counts as 1 Target Device even when communicating with multiple PLCs on either of the two DH+ networks per DHRIO.</p> <p>Note 5 – Redundant devices that use two PCDI Master blocks count as only one device. Secondary test messages do count in the messages per second for C300 performance estimation.</p> <p>Note 6 – PCDI impact on C300 performance can be estimated with the C300 Performance Model worksheet (see section 2.3.4); important factors are number of PCDI Master blocks, number of PCDI Request block messages per second, and message data size.</p> <p>Note 7 – Incoming peer data benefits from the RBE (Report by Exception) comparisons done at the data source, so only changed parameters contribute to the incoming PPS load.</p> <p>Note 8 – Outgoing peer data capacity is defined/measured before the RBE (Report by Exception) comparisons are done, so all parameters requested as peer data contribute to the outgoing PPS load, whether they are changing or not and sent over the network or not.</p> <p>Note 9 – CDA Peer connection to a redundant SM consumes 2 PCUs.</p> <p>Note 10 – PCDI Licenses per Server is limited to 256 total PCDI Device Blocks for all C300s and ACEs combined.</p> <p>Note 11 - Float, integer, or BOOLEAN values configured constitute one parameter</p> <p>Note 12- Number of PIOMB blocks that can be instantiated or loaded to the C300 is limited by the C300 CEE memory, and CPU.</p> <p>Note 13- Overlap between controller CDA peer and display responder requests was removed for C300v2 and C300E in R510 release to prevent loss of peer communication during high display subscriptions from process operational displays.</p>		

2.3.4 C300 Processing and Memory Capacity Model

The C300 Processing and Memory Capacity Model has been developed to identify the major factors that influence the performance of the C300 Controller.

2.3.4.1 C300 Processing

The Figures below provides a simplified view of C300 Controller CPU usage. CPU in the C300 Controller is primarily used for three purposes – executing control strategies, communicating with the IO Links, and communicating with other entities outside the C300, such as peer nodes and displays.

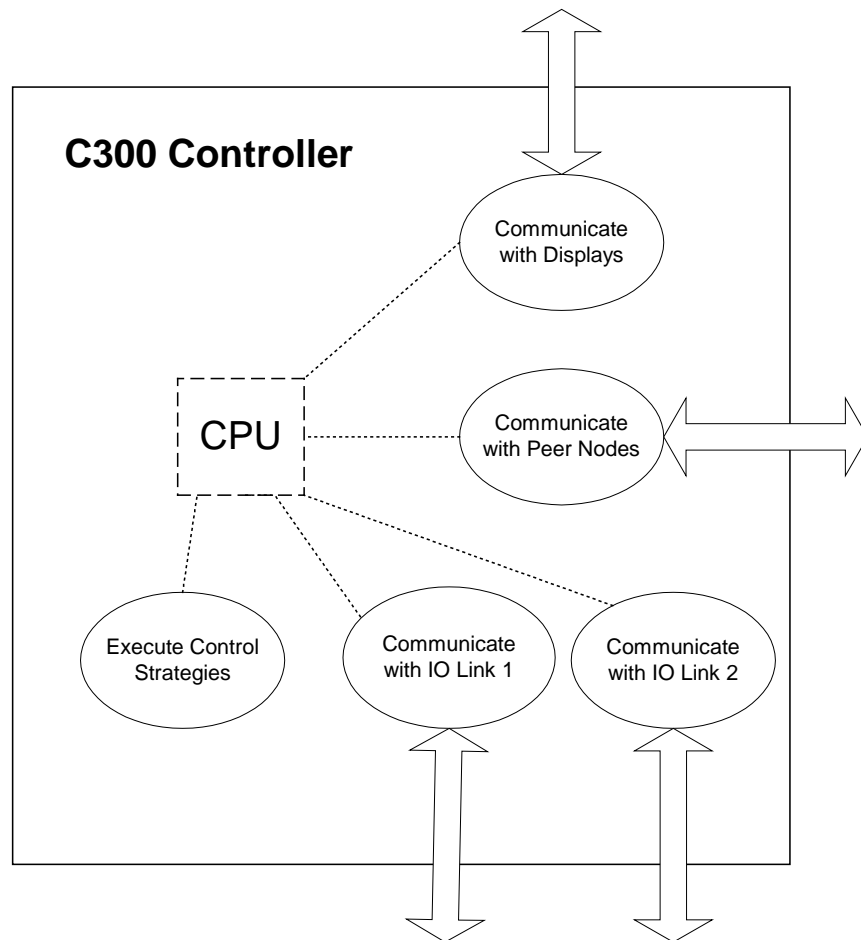

Figure 2.3.4.1 - C300 CPU Usage

The key specification for C300 performance is as follows.

- C300 – 50ms has **5500 XUs available** for user Control, IO, and Communication needs
- C300 – 20ms has **5000 XUs available** for Control, IO, and Communications needs, although various operations and strategy configurations will contribute added XU weights to the calculations in this higher speed CEE (See note below)

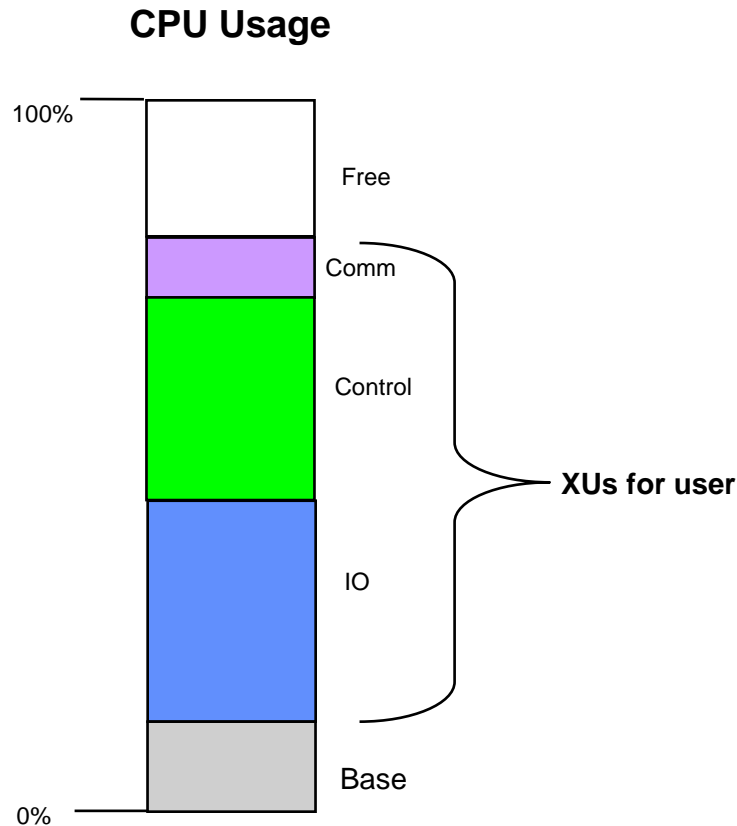

Figure 2.3.4.1 - C300 XUs Available to User

2.3.4.2 C300 Control

Control requirements of a C300 are estimated in PUs, using a PU estimation spreadsheet similar to those used for C200 and ACE. The definition of a PU (see Section 1.4) does not change with the introduction of C300, because the PU definition is platform independent. C300 PU specifications are provided for the same set of typical module types (e.g. Small Analog Data Acquisition CM, Regulatory Control CM, Device Control CM, etc.) as already documented for C200 and ACE.

PU specifications are not provided for Series C IO Modules and PM IO Modules, because the IO Module execution for these IO types is not part of CEE. Processing load attributed to the execution of Series C IO Modules and PM IO Modules is accounted for in the IO component of C300 CPU usage.

2.3.4.3 C300 IO

Performance testing has determined that the following factors have the greatest influence on the amount of CPU used to support and communicate with IO.

- IO Link 1 Type – PM IO, Series C IO, or None
- IO Link 2 Type – PM IO, Series C IO, or None
- IO Link 1 LUs – estimated from LU estimation sheet
- IO Link 2 LUs – estimated from LU estimation sheet
- Number of FTEB supported IO modules

The C300 performance model estimates the XUs required to support IO, when provided with estimates for the above factors.

The LU estimation worksheet contains all the details needed to estimate the LUs associated with a given IO Link and its complement of PM IOPs or Series C IOMs. To summarize, the number of LUs is dependent on the following items.

- Link Type - PM IO or Series C IO
- Number of IO Modules, and for each its type (AI, AO, DI, DO, etc.), scan rate, and redundancy configuration
- Number of AO connections – quantity and rate
- Number of DO connections – quantity and rate
- Number of SCM reads and writes per second of IO Link data

2.3.4.4 C300 Communication

Performance testing has determined that the following factors have the greatest influence on the amount of CPU used to communicate with peer nodes and displays. A conscious effort has been made to keep the number of input factors to a minimum to keep the C300 performance model as simple as possible while maintaining its usefulness and accuracy. The model has been refined to the point that only these major factors need be input to the spreadsheet. The XUs required to support the specified communications are calculated automatically from these inputs.

- # of Peer Connections (node type is not critical) – nodes considered as peers include C300, C200, ACE, FIM4
- # of Console Stations associated with Experion Server/cluster
- # of Parameters per second for display throughput
- # of Messages per second
 - # Messages/second is calculated from the number of Exchange blocks, Push block stores, and SCM block stores that initiate and respond to requests

The number of Notifications per second generated by a C300 is an example of a factor not included in the model because it is not significant when compared to the other factors listed above.

2.3.5 C300 Memory

Memory Units (MUs) are used to measure the amount of User Memory available and consumed. MUs required for typical strategies are provided below.

2.3.5.1 C300 Memory Resources

C300 Memory Resources and Block Configuration	
Total Available C300 CEE User Memory (TOTALMEMINK) ²	14,852 MU
Maximum Total Number Tagged Blocks Configurable per C300 CEE (CMs, SCMs, RCMs, and IOMs) ²	4095
Maximum Number of Component Blocks per CM ¹	100
Maximum Number of Component Blocks per SCM/RCM/MR	400
Maximum number of parallel paths executing in SCM/RCM/MR simultaneously	15
Definition: MU = Memory Unit = 1 Kbytes = 1024 bytes	
Note 1 – Component blocks include basic blocks and contained CMs/SCMs/RCMs/MRs	
Note 2 – CEE and C300 Platform blocks are also tagged blocks.	

2.3.6 C300 CEE Block Processing & Memory Usage Models

C300 Typical Processing and Memory Resource Capacities		
Typical Module Types (FB Content in Parenthesis)	Processing Resource Consumption ¹ (Per Module)	Memory Resource Usage
	50 ms C300 (PU/Module Execution)	50 ms C300 (MU/Module)
Typical I/O Module (Average consumption of available IOMs)	0.2	0.5
Analog Digital Acquisition Module (10 AI, 10 DataAcq FBs)	4.4	7.2
Small Analog Data Acquisition Module (1 AI, 1 DataAcq FB)	0.5	1.0
Regulatory Control Module (1 AI, 1 DataAcq, 1 PID ⁴ , 1 AO, 6 Logic FBs)	3.1	3.8
Auxiliary Function Module (10 Aux. FBs, such as AuxCalc, Totalizer)	5.0	6.2
Digital Data Acquisition Module (10 DI, 10 Flag FBs)	1.2	1.5
Small Digital Data Acquisition Module (1 DI, 1 Flag FBs)	0.2	0.5
Device Control Module (2 DI, 2 DO, 1 DevCtl, 5 Logic FBs)	1.3	2.3

<p>Logic Control Module (20 Logic FBs)</p>	1.3	3.6
<p>Sequence Control Module A (1 each of Main, Hold, Stop and Abort Handlers, 10 Steps with 8 Outputs each, 10 Transitions with 5 Conditions each, 10 Recipe items, 5 History items) SCM has total of 10 Steps and 10 Transitions among the 4 Handlers</p>	6.0	21.0
<p>Sequence Control Module B (1 Main Handler, no other Handlers, 20 Steps with 4 Outputs each, 20 Transitions with 3 Conditions each, 10 Recipe items, 5 History items) SCM has total of 20 Steps and 20 Transitions</p>	2.6	18.8
<p>Sequence Control Module with an alias table of size 45 rows by 100 columns (1 each of Main, Hold, Stop and Abort Handlers, 10 Steps with 8 Outputs each, 10 Transitions with 5 Conditions each interspersed in all the handlers, 10 Recipe items, 5 History items) SCM has total of 10 Steps and 10 Transitions among the 4 Handlers</p>	5.0	151.5
<p>Sequence Control Module with an alias table of size 500 rows by 9 columns (1 each of Main, Hold, Stop and Abort Handlers, 10 Steps with 8 Outputs each, 10 Transitions with 5 Conditions each interspersed in all the handlers, 10 Recipe items, 5 History items) SCM has total of 10 Steps and 10 Transitions among the 4 Handlers</p>	5.0	156.3
<p>Recipe Control Module A (1 each of Main, Hold, Stop and Abort Handlers; each handler has 1 Invoke transition with 5 Conditions. Main Handler contains 1 Step with 8 outputs, 4 Synch blocks, and 2 Transition blocks with 1 Condition each, and 10 Phase blocks with 25 Formula parameters and 25 Report parameters each.) The RCM executes 5 Phases in parallel.</p>	4.8	30.4
<p>Recipe Control Module B (1 each of Main, Hold, Stop and Abort Handlers; each handler has 1 Invoke transition with 5 Conditions. Main Handler contains 1 Step with 8 outputs, 4 Synch blocks, and 2 Transition blocks with 1 Condition each, and 10 Phase blocks with 25 Formula parameters and 50 Report parameters each.) The RCM executes 5 Phases in parallel.</p>	2.8	19.3
<p>Medium sized CDB Module (CM with 1 medium sized CDB instance). CDB instance has a total of 15 Custom Data Parameters of which 2 are arrays: 5 32 char. STRING; 4 scalar FLOAT64;</p>	0	1.5 ² 1.0 ³

<p>4 scalar BOOLEAN; 1 20 element FLOAT64 array; 1 20 element BOOLEAN array.</p>		
<p>Note 1 – Total Processing Resources (PU/sec) per module are computed as = Processing Resource Consumption (PU/module execution) / Execution Period (sec/module execution).</p> <p>Note 2 – Memory usage for first module instance.</p> <p>Note 3 – Memory usage for every subsequent module instance.</p> <p>Note 4 – For PID-PL use 1.4 X the PU values listed here.</p>		

2.3.7 IOLIM Communication Specifications

IOLIM Communications Performance	
Maximum Total Parameter Access Response Rate ¹	6000 PPS
Maximum IOLIM to CEE Parameter Access Response Rate (PEERRATEAVG and PEERRATEMAX)	5120 PPS (Max 1280 channels @ 250 ms publish rate)
Maximum number of Display Parameters per IOLIM (DISPRATEAVG and DISPRATEMAX)	1000 PPS
Maximum Initiator Node Pull/Get Request Rate ² (PEERINITAVG and PEERINI AX)	1000 PPS (Restricted by Link Unit limit of 1000, assuming 1 Link Unit = 1 parameter/sec.)
Maximum Target Node Response Rate to Push/Store Requests ³	50 PPS
<p>Note 1 – Includes all Server Data Requests and peer communications to local C200/CPM</p> <p>Note 2 – IOLIM update rate from CEE is fixed at 100 ms.</p> <p>Note 3 – Currently the SCM Step Output and the Push FB are the only blocks that can initiate push/store requests from CEE to IOLIM.)</p>	

2.3.8 C300-20 and C300-50 Functional Comparison

The C300 20ms Controller has been functionally constrained to allow it to fulfill [Turbo Machinery Control Application](#) requirements only. The following Table describes these constraints:

Function	C300 50ms	C300 20ms
Series C I/O	Supported up to max IOU limit	Supported – Max of 12 IOMs total and max of 8 IOMs/IO Link Not Supported- Series C Mark II IOs.
PM I/O	Supported	Not Supported - blocked during assignment in the Control Builder
FIM4 & FIM8	Supported	Not Supported – blocked during assignment by Control Builder
PGM	Supported	Not Supported – blocked during assignment by Control Builder
SIM C300 (simulation)	50 ms Supported	20 ms Not Supported - Simulation Environment for a C300 20ms Controller configuration is blocked during load by Control builder.
EBM functions 1. SCM 2. RCM 3. UCM 4. PHASE	Supported	Not Supported - All these blocks are blocked for a C300 20ms Controller during assignment in the Control Builder.
Series A Chassis IO Modules	Supported	Not Supported
Series A & H Rail IO Modules	Not Supported	Not Supported
CCL Library Blocks	Supported	Not Supported
CAB	Supported	Supported
CDB	Supported	Not Supported - The CDB Function blocks are blocked during assignment in the Control Builder for a C300 20ms Controller.
PCDI Blocks	Supported	Supported – limited capacity (See section 2.3.3 for limits) and specific use for 3 rd Party DCS Integration only.
Exchange Blocks	Supported	Not Supported - blocked during assignment in the Control Builder
JAGXTREME	Not Supported	Not Supported
QIMPACT Library -- QIPACCHAN QIPACTERM	Not Supported	Not Supported
Series C Servo Valve Positioner Module	Not Supported – Blocked by CB for C300 50ms controller	Supported – Allowed for Turbine Control Applications up to the limits specified.
Series C Speed Protection Module	Not Supported – Blocked by CB	Supported – Allowed for Turbine Control Applications up to the limits specified.
Profit Controller Integration	Only Supported on CC-PCNT02	Not Supported
Ethernet Interface Module	Only Supported on CC-PCNT02	Not Supported

3.0 Engineering Tools Performance Specifications

The following subsections define the key terms used in the Engineering Tools performance specifications; provide the actual specifications and several special considerations.

3.1 Terms

Underlined words or phrases in the subsequent tables are defined in this section:

Engineering Tools Performance Terms	
Contained Block	<p>May include the following block types:</p> <p>For SCM or RCM: handler, phase, step, transition, sync;</p> <p>For CM: basic block.</p>
Typical Control Module (CM)	A CM that contains an average of 12 basic blocks, including one regulatory control block and related channel/logic blocks.
Typical Automated Sequential Control Module (SCM)	An SCM that contains 200 contained blocks, 8 step outputs per step, 5 conditions per transition.
Typical Procedural SCM	An SCM that contains 100 contained blocks, 4 instructional outputs per step, 3 conditions per transition.
Typical Recipe Control Module (RCM)	An RCM that contains 100 contained blocks. 60% of these will be phase blocks. A typical Phase Block would contain 5 Formula + 5 Report parameters.
Mixed Typical Objects	<p>The distribution of "mixed typical objects" is as follows:</p> <p>70% typical CMs, 10% typical automated SCMs, 10% typical procedural SCMs, 10% typical RCMs.</p>
Database Operation	Any client operation that accesses the ERDB for either reading or writing
Significant Database Operations (SDO)	<p>Any operation that modifies or utilizes the database, including load, load while active, upload, update-to-project, delete, force delete, copy/paste, import, export, assign, un-assign, bulk edit, bulk build, check-in, check-out, FDM tag building, parameter search (especially when using wildcard symbols * or?), EHPM parameter import, Engineering Data Builder, Project Engineering, and PROFIBUS Automatic Slave Configuration</p> <p>Significant database write operations lock the objects they operate on.</p> <p>Operations deemed not significant include: Make Template, Load Server Points, Point Picking, Tag Validation, etc.</p>
Controller-related Database Operations	Any operation that involves communication with a controller. Includes: Load, Delete, Upload, Checkpoint save, Checkpoint restore, Checkpoint rebuild, and Bulk Edit of Monitor-side operations, and On-Line Search.
QVCS-validated Operations	<p>Bulk Edit, Assign, Un-assign, Rename, Delete, Force Delete, Load, Upload, Update-To-Project, Import.</p> <p>QVCS validation occurs whenever locks are requested on the database objects.</p> <p>Validation occurs on all objects, regardless of whether they are checked in to QVCS or not.</p>

Tagged Object	Any object that can be referenced as a point from the operational displays.
Client	Enterprise Model Builder, Control Builder, FDM Tag Builder, Applications using the Config API interface (the interface is not externally available; only Honeywell applications can use the Config API)
Typical Engineering Repository Database Size	A typical Engineering Repository database may contain Maximum number of 30000 Mixed Typical Objects

3.2 Tools Performance Specifications

A clean start of Control Builder is assumed for all the following specifications. Continued use of a single Control Builder process instance for significant database operations results in a buildup of memory allocated to the Control Builder process. Periodic closing and re-starting of the Control Builder application are recommended to minimize the effects of the buildup in memory usage. The concerns noted above for Control Builder also apply to applications using the Config API interface.

Engineering Tools Performance Specifications		
Rule #	Description	Limit
1	Maximum number of <u>tagged objects</u> for which <u>database operations</u> can be performed, when more than one <u>client</u> is in use up to the maximum number of clients allowed. ⁶	100
2	Maximum number of <u>typical CMs</u> for which <u>database operations</u> can be performed, when one <u>client</u> is in use, with exceptions noted below.	1000
2.1	Maximum number of <u>typical automated SCMs</u> , <u>typical procedural SCMs</u> , or <u>typical RCMs</u> for which <u>database operations</u> can be performed, when one <u>client</u> is in use, with exceptions noted below.	100
3	Maximum time to complete <u>significant database operations</u> performed on 100 <u>typical CMs</u> ⁶	20 minutes
4	Maximum time to complete <u>significant database operations</u> performed on 100 <u>mixed typical objects</u>	110 minutes
5	Additional time required for <u>QVCS-validated operations</u> to be performed when the tagged objects are under QVCS management	10%
6	Maximum number of Control Builder <u>clients</u> that can be supported and licensed per cluster	12
7	Maximum number of <u>clients</u> that can simultaneously perform <u>significant database operations</u> with execution time increases linearly with each additional client. ⁷	6
8	Maximum number of <u>clients</u> that can simultaneously perform <u>significant database operations</u> with no execution time guaranteed. ⁷	8
9	Maximum time to complete template propagation for 100 objects (<u>typical CMs</u> , <u>typical automated SCMs</u> , <u>typical procedural SCMs</u> , or <u>typical RCMs</u>)	60 minutes
10	Maximum number of <u>clients</u> that can perform <u>controller-related database operations</u> on the same controller at the same time ^{1,2}	1
11	Maximum number of <u>mixed typical objects</u> exported or imported in a single operation ³	25,000
12	Maximum time to complete an import of 700 <u>mixed typical objects</u> , using only one <u>client</u> ³	180 minutes

13	Maximum time to complete <u>significant database operations</u> performed on 100 <u>typical automated SCMs</u>	240 minutes
14	Maximum time to complete <u>significant database operations</u> performed on 100 <u>typical procedural SCMs</u>	240 minutes
15	Maximum time to complete <u>significant database operations</u> performed on 100 <u>typical RCMs</u>	240 minutes
16	Maximum number of <u>typical CMs</u> bulk built in a single operation with a single CB <u>client</u> .	700
17	Maximum time to complete a bulk build of 100 <u>typical CMs</u>	40 minutes
18	Maximum number of <u>automated SCMs</u> bulk built in a single operation	100
19	Maximum time to complete a bulk build of 100 <u>automated SCMs</u>	640 minutes
20	Maximum number of FIM2s, FIM4s, or FIM8s that can be loaded in a single operation	25
21	Maximum number of FTE nodes for which firmware can be loaded in a single load operation	100
22	Maximum number of tagged objects included in Checkpoint Rebuild operation (which is selected on the whole controller(s) basis only)	5000
23	Maximum number of Object Linking and Embedding (OLE) objects recommended per control chart(CM/SCM/RCM)	20
24	Maximum number of characters allowed to configure the name of a tagged object ⁴	40 characters
25	Maximum number of characters allowed to configure expression in expression supported blocks	1024 characters
26	Maximum time to complete significant database operations on Master Recipe template with 100 blocks and 3 level derivation hierarchy	1 minute
27	Maximum number of inheritance hierarchy beyond the system template ⁵	3 level
28	Maximum number of Master Recipe instances supported per Master Recipe Template	20
29	Maximum time to complete database read operations for a tagged object and or a function block	< 2 minutes
30	Maximum number of instances supported per Template	200

Note 1 – Controller-related database operations attempted by 2 clients on the same database object at the same time are prevented.

Note 2 – Includes any Config API clients that perform controller-related database operations.

Note 3 – Not recommended to use server for significant database engineering operations. For import and export of entire ERDB of 25K points , the CB Client should be running on the primary ERDB Server (Server B in a redundant Server configuration)

Note 4 - Maximum size of FTEB, Wireless device name, and server alias name is restricted to 16 characters and FF device name is restricted to 32 characters.

Note 5 - The software does not limit the number of levels of derivation, although opening, editing, and saving a parent template with many sub-templates and derived instances may be slow due to the time involved in locking all the derived blocks and propagating all changes.

Note 6 - Close and reopen control builder to reduce the memory footprint before performing the significant Engineering database operations

Note 7 – Not supported to use more than one Control Builder instance per Experion node

4.0 C300 I/O Capacities

C300 IO Capacity Table		
	50 ms CEE	20ms CEE
Maximum Number of IO UNITS per C300 ^{1,2,4}	64 <i>(See Note 4)</i> 80 <i>(if using PM IOPs/Series C IOMs only)</i>	12
Maximum Number of IO UNITS per C300 IO Link	40	6 ⁴
SERIES A IO-RELATED ONLY:		Not Supported
Maximum Number of Series A IO Chassis connected through FTEB per C300	8 ³	NA
Maximum Number of IO UNITS per Series A IO Chassis/FTEB	16	NA
Maximum Number of Serial Interface Modules per C300	3	NA
Maximum Number of Serial Interface Modules per FTEB	1	NA
Maximum Number of DeviceNet Modules per C300	12	NA
Maximum Number of DeviceNet Modules per FTEB	4	NA
Maximum Number of SST Profibus Modules per C300	10	NA
Maximum Number of SST Profibus Modules per FTEB	4	NA
FF FIM4-RELATED ONLY:		Not Supported
Maximum number of Redundant or Non-Red FIM4s per C300 ¹	15	NA
Maximum number of Redundant or Non-Red FIM8s per C300 ¹	8	NA
PGM2-RELATED ONLY:		Not Supported
Maximum number of Redundant or Non-Red PGM2 per C300 ¹	4	NA
Note 1 – See Section 4.1.1 IO UNIT Definition Table for detail IO Units for each IO type supported. Note 2 – Specific IO Devices may be further limited as described elsewhere due to Link Units or IO Buffer limits or other constraints Note 3 – Because the FTEB has to connect to the same Control Firewall as the C300, this may be further limited by the number of available ports on the Control Firewall Note 4 – Normal C300 50ms IO Limit is 64 IOUs with any combination of Series C (IOMs, FIMs, PGMs), Series A, and PM IOPs. If using PM IOPS or Series C IOMs only, the limit is extended to 80 IOUs (IOPs).		

4.1 IO UNIT Definition Table

The following Table defines the **IO UNIT** load factor for the various I/O Devices supported by the C200, C200E, and C300:

I/O UNIT Definition Table	
IO Device or Module	IO Units
1 PM IOP Module ¹	1

1 Series C I/O Module ²	1
1 Serial Interface Module (SIM) per FTA ⁴	4 for C200/C200E 6 for C300
1 Pulse Input Module (PIM)	C300: 1.5 (for 64 Unit/CPM limit) 1.5 (for 16 Unit/FTEB limit)
1 Series C Fieldbus Interface Module (FIM4) ⁵	4
1 Series C Fieldbus Interface Module (FIM8) ⁵	8
1 non-redundant Fieldbus Interface Module (FIM2)	2 (for 64 Unit/CPM limit) 3 (for 24 Unit/CNI limit)
1 Redundant Fieldbus Interface Module Pair (Red-FIM2)	2 (for 64 Unit/CPM limit) 4 (for 24 Unit/CNI limit)
1 DHRIO Module	1 (for 24 Unit/CNI Limit) 0 (for 64 IOU limit)
1 (1203-CN1) AB Drive Controller	1
1 SST-PFB-CLX Profibus Module	C300: 4.5 (for 64 Unit/C300 Limit) 3.5 (for 16 Unit/FTEB Limit)
1 DeviceNet Bridge Module (DNB)	C300: 4 (for 64 Unit/C300 Limit) 3.5 (for 16 Unit/FTEB Limit)
1 Source or Destination Device on Auxiliary Exchange peer to peer network	1 (for 24 Unit/CNI Limit)
<p>Note 1 – For redundant IOPs, each pair of IOPs counts as 1 IO Unit.</p> <p>Note 2 – For redundant IOMs, each pair of IOMs counts as 1 IO Unit.</p> <p>Note 3 – Except where alternate IOUs are noted elsewhere below</p> <p>Note 5 – For SIM using both FTAs, this count is doubled to 8 & 12 IOUs respectively</p> <p>Note 6 – Same IOU count whether Redundant or Non-Redundant</p>	

Experion® is a registered trademark of Honeywell International Inc.

All other products and brand names shown are trademarks of their respective owners.

This document contains Honeywell proprietary information. It is published for the sole usage of Honeywell Process Solutions' customers and prospective customers worldwide. Information contained herein is to be used solely for the purpose submitted, and no part of this document or its contents shall be reproduced, published, or disclosed to a third party without the express permission of Honeywell International Inc.

While this information is presented in good faith and believed to be accurate, Honeywell disclaims the implied warranties of merchantability and fitness for a particular purpose and makes no express warranties except as may be stated in its written agreement with and for its customer.

In no event is Honeywell liable to anyone for any indirect, special or consequential damages. The information and specifications in this document are subject to change without notice.

For more information

To learn more about Honeywell's products or solutions visit our website www.honeywellprocess.com or contact your Honeywell account manager.

Automation & Control Solutions

Process Solutions
Honeywell

1250 West Sam Houston Parkway South
Houston, TX 77042

Honeywell House, Arlington Business Park,
Bracknell, Berkshire, England RG12 1EB UK

Shanghai City Centre, 100 Junyi Road
Shanghai, China 20051

www.honeywellprocess.com

Honeywell Internal

EP03-300-511
July 2019
© 2017 Honeywell International Inc.
Honeywell Proprietary

Honeywell

July 2019